

# THE LOGGER'S BARK

a magazine

## Radio Club of Tacoma



The Tube Issue

## In this issue:



- **Tube Testers—Demystified** [p. 53](#)
- **WW2 POW Canteen Shortwave receiver** [p. 83](#)
- **W7DK Summer Picnic—the Time is Upon us!** [p. 25](#)
- **Radio Hospital: 1950s Elmac PMR-6A tube receiver!** [p. 79](#)
- **Tube Transmitter Kits: not ONE but TWO!** [p. 91,](#) [p. 93](#)
- **RARE: 1913 Tungar Diode Tube Charger found in attic!** [p. 110](#)
- **Fun Stuff: The Tube That Never Was & The “Milkotron”** [p. 68,](#) [p.71](#)
- **Ham Tech 101: The Basics of Tubes & How They Work** [p. 117](#)
- **Sherlock Returns: Radio Failures in Three Acts!** [p. 49](#)
- **G3EDM Homebrew Tube Hiking Rig “Peashooter”** [p. 94](#)

### Cover:

Fully restored Heathkit TC-2 Tube Tester from the 1950s with an 807 tube under test. The meter shows the AC Power Level centered

Photo by W7UUU



**W7DK 2025 OFFICERS  
AND COMMITTEE LEADERS**

**EXECUTIVE COMMITTEE:**

- President:** Adam Barbera W2NCC
- Vice President:** Mike Isakson W7XH
- Secretary:** Gary McAdams WG7X
- Treasurer:** (Acting) Doug Schafer AB7DG

**BOARD OF DIRECTORS:**

- Board:** Mike Drorbaugh W7MKE
- Board:** Paul Matney W7PFU
- Board:** Doug Schafer AB7DG
- Board:** Dan Vacanti KD7SV
- Board:** Dave Ashley W7GEL

**KEY COMMITTEE CHAIRPERSONS:**

- Membership:** Mike W7XH
- Salmon Run:** Mike W7XH
- Infotech/IT:** Randy WB4SPB
- HF Operations:** Phil K7PIA
- Facilities:** Adam W2NCC
- Property Mgmt.** Red WB7EC
- Museum:** Dan KD7SV
- Planning:** Mike W7XH
- POTA:** BJ KO7T
- General Meeting:** Dave W7UUU
- Bark layout & Editor:** Dave W7UUU
- Assistant/Copy Editor:** Anne N7ANN

**CONTENTS**

**QUICK LINKS TO THE BIG STUFF!**

<a href="#">PAGE 3</a>	<a href="#">PRESIDENT'S CORNER</a>
<a href="#">PAGE 4</a>	<a href="#">FROM THE DESK OF THE VP</a>
<a href="#">PAGE 5</a>	<a href="#">THE SECRETARY'S REPORT</a>
<a href="#">PAGE 8</a>	<a href="#">MEMBERSHIP REPORT</a>
<a href="#">PAGE 9</a>	<a href="#">EDITORIAL</a>
<a href="#">PAGE 10</a>	<a href="#">GUEST EDITORIAL</a>
xx	PLANNING COMMITTEE
<a href="#">PAGE 12</a>	<a href="#">HAM RADIO WORLD NEWS</a>
<a href="#">PAGE 13</a>	<a href="#">ARRL NEWS &amp; VIEWS</a>
<a href="#">PAGE 14</a>	<a href="#">LETTERS TO THE EDITOR</a>
<a href="#">PAGE 123</a>	<a href="#">BOARD OF DIRECTORS MINUTES</a>
<a href="#">PAGE 129</a>	<a href="#">GENERAL MEETING MINUTES</a>

**But don't stop there! Each issue is 100 or more pages of fun and cool stuff to explore! Scroll on!**

xx=nothing submitted

# PRESIDENT'S CORNER

## Monthly ruminations from our President

Adam  
Barbera  
W2NCC



### RADIO CLUB OF TACOMA ENDOWMENT FUND

Last month, a proposal was brought to the board to establish an Endowment Fund—a new and forward-thinking way to support the Radio Club of Tacoma, both today and for generations to come.

The idea isn't entirely new. Members have expressed interest for years in creating a long-term fund that would ensure the club's future. Now, that vision could become a reality with the creation of the W7DK Endowment Fund.

Unlike the general fund—where donations are used to meet current needs—the Endowment Fund would work differently. Contributions would be invested, not spent. Only the investment earnings—such as interest and dividends—would be used to support the club's operations. The original gift, or principal, would remain intact. That means your donation would continue to benefit the club year after year, indefinitely.

To establish the Endowment Fund, a minimum of \$10,000 would be required. The fund would be set up as a separate legal entity, distinct from the club's general assets, with independent oversight and professional financial management. The principal

would be permanently protected. Only the annual earnings would be distributed to the club. This structure ensures a strong legal safeguard for the funds and creates a perpetual legacy. And most importantly, the board would have *no access to the*

*principal*—only the earnings would be made available each year.

Why does this matter? If approved by the board, in my opinion, this would be an historic milestone for W7DK. The Radio club of Tacoma Endowment Fund would be more than just a

new account. This represents a new way to think about supporting the club. It's about creating a legacy that lasts for generations, into the next 100 years, ensuring future members may enjoy the same great experiences we have today. Additional details will be presented at the next board meeting.

73,  
-Adam C. Barbera, W2NCC  
President





**GREETINGS—FOR THOSE WHO DON'T KNOW ME,** my name is Mike Isakson. I've been a member of the club since 2014, and I was recently appointed Vice President by Adam, **W2NCC**.

Our previous Vice President, Manny **AD7MA**, stepped down for personal reasons. The club will certainly miss Manny's leadership and direction.

**My introduction to ham radio** goes all the way back to my grandfather's shack in the late 1950s. He was not the most approachable man, and never particularly encouraging. Unfortunately, his attitude turned me away from ham radio for many years. It wasn't until 2010 that the spark came back. I was at the Puyallup Fair (now called the Western Washington Fair) and happened to meet John Clarke **AC7WW** from the Radio Club of Tacoma in the club's booth in the Hobby Hall. Over the next four years, he encouraged me to visit the club and take the Technician class. As they say, the rest is history. I passed both my Technician and General class exams and joined the club—only to discover later that my grandfather had once been a member as well.

**Over the past several years,** I've served as Membership Chairman and have been responsible for all club mailings—membership renewals, Salmon Run, and club ballots. I'll continue in that role. I've also recently accepted the position of Chairman of the Planning Committee. The work that began under Manny's leadership is continuing. The committee has already held two meetings—one in June and another just a few weeks ago, in July.

My goal is to support the club and its members to the best of my ability. Those of you who come to the Saturday open house know I tend to speak my mind. But my ultimate desire is to do good for the club—both now and in the years to come.

In the January 2025 *Logger's Bark*, Manny shared these thoughts:

**“As we look to 2025, I encourage every member to reflect on three key priorities:**

- Acknowledge and honor the contributions of our senior members. Their dedication and expertise are invaluable to the Club.
- Embrace emerging technologies and perspectives from younger hams to ensure our continued growth and relevance.
- Bridge generational divides by fostering mutual respect, open dialogue, and collaboration to unite our membership in shared success.

The Radio Club of Tacoma has thrived for over a century. It is our shared responsibility to ensure it not only survives but grows stronger, setting the stage for another 100 years of excellence in amateur radio.”

I share those same beliefs. It's our duty to build a great club and a strong community—our history demands it. With a membership of over 400, we're teaching and training, learning new technologies, and building connections. Together.

I look forward to serving all of you.

—Mike Isakson **W7XH**

# SECRETARY'S REPORT

W7DK Secretary—Gary WG7X



## KEEPING THE LIGHTS LIT AT W7DK

Yesterday, July 2<sup>nd</sup> we had the July Board of Directors meeting as we do every month. All the officers, but one were there in person and via Zoom. All went as usual until the subject of funding the club going forward.

As many of you should know, the club has more than one way to generate funding.

- Yearly dues
- Property management
- Salmon Run
- Special Events
- Random Donations

**Let's start with the yearly dues fees.** Currently, the basic membership fees are \$35 for full membership under 65 years of age. Seniors pay \$30 and there are three other levels of membership that only run \$20.

Folks, this is not going to be enough to keep the lights on much longer. We ran the numbers during the meeting. We all know that everything about having property keeps going up and up. There is a lot involved in the day-to-day of having a club and making it work.

All this to say that membership fees are going to have to go up. Its inevitable. The last time we raised the fees was in 2015. Ten years makes a lot of difference. Then, we only went up \$5.00, this time it's probably going to be \$10.00. This is still being considered and won't be going up until 2027 at the earliest.

**Then there's Property Management.** Our property management team does a great job in managing current property and selling the surplus stuff that keeps coming in. They have brought in a major amount of funds over the years. Check them out on any Saturday. They usually are in the garage doing triage on the latest donations. Club members get the first opportunity to purchase donated equipment before it is sold at a hamfest.

## Next is everyone's favorite target: Salmon Run.

A little history first. Way back in the misty past, the Radio Club of Tacoma sponsored a big hamfest. It was usually held at Pacific Lutheran University and at first a lot of money was made for the club, but as time went on, it became increasingly difficult to maintain, especially when we could no longer hold it at PLU. At the end it became a year-long event to plan and carry out. A years' worth of time and energy for very little return.

So, we began looking for other ways to generate funds to keep the club going and to have funds for other club activities. One of our members, Al **N7OMS**, came up with the idea of using the WWDXC Club's annual Washington state QSO party to generate funds.

The idea was that we would solicit pledges from interested club members for making contacts in all thirty-nine Washington counties. Each member was free to designate how much they would donate per county worked.

This idea was implemented and became not only

# SECRETARY'S REPORT

W7DK Secretary—Gary WG7X



one of the main funds generating events ever, but it was also great fun to try to get the “Clean sweep” of all 39 counties every year, which is not easy.

**The money that came in from the salmon run** was not for any specific thing at the club; it was cash that we could use for whatever the club needed. If I remember correctly, the first year, the cash was used for improvements to the clubhouse, then for a new shed, and so on.

Things began getting complicated when some folks started misunderstanding the whole reason for the Salmon Run participation in the first place, which was just to generate income for whatever the club needed.

**This came to a head last year**, when the HF committee asked for money to replace certain pieces of equipment that needed to be replaced. Mostly because they were old and getting harder to maintain.

The hardest equipment to maintain were the two Drake L4-B amps that the club owned. These were big desktop amps that had been used hard by the club over quite a few decades and they were showing the wear. We needed to replace them. So we began looking at the equipment in the three HF stations with an eye to begin finding out how much this was going to cost and how we could do it without spending a lot of cash.

**During this time two things happened.** First, Adam W2NCC began finding folks to donate excess equipment to the club to sell. Adam did this on his own, without any help because he wanted to replace the

club's Elecraft K3 with a better, easier to use modern radio. He did not use a penny of the club's funds to do this. He caught a lot of flak from people who did not know what the actual string of events was. So now we have a new IC-7610 for people to use courtesy of Adam W2NCC.

**The second thing that happened** was that one of our long-time members, PJ N7PH, passed away and donated his entire ham radio estate to the RCT. This was an amazing thing for him to do, and he knew that we would use his stuff the way it was intended to be used and that we would not sell it off.

So, thanks to PJ we now have a complete Flex radio setup complete with a Mercury III's amp and tuner.

The only thing to do then was to finish updating the Icom station. That year, the club had an amount of cash in our accounts and after much thought we asked for and received funds to buy a Palstar amp and tuner and bandpass filters that would allow us to operate all three clubhouse HF stations at the same time at high power, something that we had never had the ability to do before.

All this was done in the open, budgets for this and other projects were announced to the membership with full transparency. Some opposition was heard, but not very much, and the project went on and was completed by the end of the year.

**Apparently though, when Adam became president** this year, some folks made a point of letting him know that, going forward, they didn't want their club fees to go toward “buying radios”. Which is a

# SECRETARY'S REPORT

W7DK Secretary—Gary WG7X



strange thing to say, since none of their club fees were used for that, it was all salmon run pledges.

**Also, it is a bit strange to hear from a RADIO CLUB MEMBER that we should not buy radio equipment...**

A clue here: we're a radio club, not a pinochle club, a car club, an airplane, ski, baseball, or any other type of club, we are the **Radio** Club of Tacoma.

So, enough about the Salmon Run funds. A total volunteer donation, meant to go for whatever the club designates it to be used for.

**Next: Special Events.** In the past RCT sponsored some special events. Most notably were the 90<sup>th</sup> anniversary and 100th anniversary of the radio club. Neither of these events generated revenue.

Starting last year though, one of our members, BJ **KO7T**, started a very fun event: the Sasquatch recognition days which was fun and paid for itself and generated a bit of revenue for the club. This event will be repeated this year and looks like it will be a great thing to get the radio club some recognition.

**Last would-be Random Donations:** Self-explanatory and very random. Occasionally we will get someone who just wants to donate cash to us. We accept it with thanks, but this cannot be depended on. It does happen often enough to be on the list though.

So, that's my story and it's all true. RCT manages to keep going for its members and because of its members' support. We couldn't do it without, you, the members...

*Thanks, and 73, Gary WG7X*

*Secretary, Radio Club of Tacoma*



*Radio (?) operator, France ca. 1925*

*Photo: public domain*

# MEMBERSHIP REPORT

Mike W7XH, Membership Chairman

Mike W7XH

**GREETINGS EVERYONE! HAPPY AUGUST FIRST!**



OUR WASHINGTON STATE QSO PARTY, KNOWN AS “The Salmon Run,” is quickly approaching. For those who are new and might not know, several years ago we started a fundraiser to coincide with [WWDXC-run event called The Salmon Run](#). Club members would pledge an amount per county—or for a clean sweep of all 39 Washington state counties. Some pledged a one-time gift instead. In our first-ever Salmon Run fundraiser, we raised enough to re-roof the clubhouse. Over the years, this effort has brought in thousands of dollars to benefit the club and its members.

We start collecting Salmon Run donations in August and continue through the end of the year. Last year, we introduced an online pledge form with the option to pay your donation instantly via PayPal. We also added a “Donate with PayPal” button on the website home page, which you can use to fulfill your pledge or make a one-time gift. I’m happy to report that the electronic option proved very popular and was used often.

RCT isn’t a hardcore contesting club. We are all about helping hams expand their horizons and try new things—and contesting may be just the thing to get your ham radio enthusiasm rolling or reinvigorated if you’ve been away for a while. We enjoy this annual event and encourage our members to give contesting a try. Everyone is welcome to participate. So keep an eye out for the opportunity to sign up and come work an hour or more if you want. We’ll have experienced operators there to help if it’s your first time. Back in 2014, it was Gary [WG7X](#), who helped me through my first contest.

Last year’s results were published in the [October 2024 Loggers Bark](#) on page 48:

**1131 QSOs**, 104 multipliers, claimed score 253,512 (includes 1000 bonus points for working Sponsor station W7DX on two modes)

**The operators who participated last year from the clubhouse:**

**K7IPT, K7PIA, KD7SV, KG7UMZ, KK7QND, N7OMS, N9MII, NG7G, W2NCC, W7ITL, W7MKE, W7UUU, W7XH, W7XTZ, W8NGS, and WB4SPB**

Each year we also recognize all the operators who help us hit our pledge goals and make this fundraiser a success. If you haven’t taken part in our annual Salmon Run fundraiser, I hope you’ll consider joining us this year. In 2024, we had 16 operators working two stations. We pulled off a clean sweep of all Washington counties and all 50 states!

**That said, we had about 40 fewer donors than in 2023.** Salmon Run is one of our three main sources of revenue—along with membership dues and proceeds from property management—so your support makes a real difference for the financial future of the club.

**I’m asking all our members to please consider participating in this year’s fundraiser.**

Back in 2007, Al [N7OMS](#), suggested pledging just 50 cents per county—a total investment of \$19.50. Whether it’s fifty cents or five dollars per county, I hope you’ll participate at whatever level you can.

If you’ve got ideas you’d like to share with the membership, please email:  
[membership@w7dk.org](mailto:membership@w7dk.org)

—Mike [W7XH](#)



**IN THE YEAR AND A HALF SINCE I BECAME EDITOR** of *The Logger's Bark*, I've received a *ton* of emails from readers around the world. A common thread has been accolades from older hams—folks in their 50s and up—who really enjoy the articles I write about “the old gear.” That’s not too surprising, given that the current average age of a licensed ham (according to the ARRL) is about 68 years. While I know *Bark* readers span a wide range—from teenagers all the way to 95-year-olds—the “center of the bell curve” surely sits right around that 68-year average, give or take.

**I'll admit it: I love old gear,** especially tube gear. It's what I cut my teeth on as a ham, starting out in 1974. And even though my shack today is loaded with state-of-the-art rigs, I still spend most of my time tinkering with the old “boat anchors”—those heavy rigs running thermionic devices (that is, tubes!).

**So for this month's issue,** I thought it only fitting to make it The Tube Issue. Much of the content inside centers on that very theme. I dug through the W7OS Doc Spike Museum and uncovered some amazing relics from the

early days of amateur radio—including a fascinating device called a “Tungsten Generator,” one of the earliest examples of tube technology I've ever come across. It features a massive diode tube—just a filament and an anode, no grid—so it can't amplify, only rectify. See the article on page 110.

**Also in this issue,** I showcase a lineup of vintage tube testers spanning from the 1940s to the final days of the tube era. You'll find articles on kits, projects, and classic literature, all centered on tube technology—including helpful links to track down parts for building simple tube-based devices yourself.

**You won't want to miss** the amazing homebrew Backpacker's Tube Rig—a three-tube superhet receiver and a two-tube, crystal-controlled transmitter, all battery powered. Its builder, Martin **G3EDM** of the village of Wye, England, spent the first weeks of July on an astonishing 120-mile hike across the English countryside, operating 40m CW along the way.

**So sit back,** pour a glass of fresh iced tea, and enjoy the August edition of *The Logger's Bark*—The Tube Issue.

—Dave, **W7UUU**



*RCA 860 Power Tetrode 100w transmitter tube!*

*In 1938 it sold for \$7.00 a copy which would be around \$160 in today's dollars.*

*From the W7DK collection  
Photo by Dave **W7UUU***

# GUEST EDITORIAL

The place to express yourself on a Ham topic



**I OFTEN FIND MYSELF WONDERING ABOUT THE** future of the Radio Club of Tacoma. Will it still exist in 50 years? Do we have a long-term goal or objective that we're working toward? If so, is it written down or shared with the membership? Does it live in our founding documents—or perhaps tucked away in an archive somewhere?

**Our charter members were deeply involved** in the broader ham radio community. They helped found the Northwest Amateur

Radio Association. Doc Spike chaired the ARRL Northwest Division convention in 1931, drawing over 200 attendees. The president of the Washington Radio Club in Washington, D.C.—Roy Cornerman—wrote to us on December 12,

1932, asking what our club was doing. Had we become a model for others?

**From the History of the Radio Club of Tacoma, W7DK:**

“In 1954, the club worked hard in helping to secure ‘ham’ license plate legislation. The Karl Weingarten (7BG) Act was passed the year Karl died. Judge William Goodloe WA7GWJ put in lots of hours in the

right places to achieve the goal.”

I don't know whether these actions were the result of formal club consensus, or simply driven by passionate individuals. But it seems to me that the club had a clear ambition—to be an influential force in amateur radio here in the Pacific Northwest. Maybe that's why we were attracting interest from D.C.

**Like many clubs, we started small**—meeting in garages, basements, and members' homes. But in 1927,

we took a bold step that few others had: we bought property to build a clubhouse. The Great Depression hit in 1929 and the economy collapsed—but even so, in 1930 a group of our members took out a loan to finish the building at 1462

South Oaks Street. At the

time, annual dues were \$7—equivalent to about \$164 today. Was that an intentional move to do something no other club in the country was doing?

**In 1939, with World War II looming** and membership declining, the clubhouse was sold. But the club didn't give up. In 1958, we purchased another property.



*The original W7DK clubhouse, 1462 South Oaks Street, Tacoma, Washington as photographed in the summer of 1931 after it was completed*

# GUEST EDITORIAL



The place to express yourself on a Ham topic

A dozen members contributed the \$2,200 down payment. I've been told the total purchase price was around \$12,000. What's amazing is that a club of just 60 members paid off that mortgage in only two years—with dues at just \$9 a year. If there was a fundraising campaign or member donation drive, there's no record of it.

**The energy and determination of those young men** faded with time. Many of our original members left the club or became Silent Keys in the next couple of decades. I've often wondered—who was the one driving the vision? Who rallied the troops?

I share all of this to remind us where we came from. And to ask again: what is our future?

**Is there a leadership role for the Radio Club of Tacoma in the Pacific Northwest?** I believe there is—if we seek it. If we set objectives that serve the region, the state, the county, the city, and our immediate community. For too long, I think we've focused inward as our community shrinks. It's time to reverse that.

**It will take work.** I think back to the GMRS presentation many of us attended last weekend. John Beaton, **K7YT**, from Manzanita, Oregon, is clearly the one driving the bus. In his area, three communities are now fully outfitted—every business, first responder, and zone leader has a GMRS radio ready to go. Training, teaching, programming, buying and distributing radios to as many people as possible. They run regular emergency prep nets. Even when people move away, they leave their radios behind for the new residents. Why? Because John had a vision.

I believe our club was meant to play that kind of role in our own community. And I've identified a few obstacles to our success—and how we can overcome them.

**We need someone to drive the bus**, with a full tank of gas. We need vision, and direction—spoken clearly, loudly, and often. We need the energy to bring everyone together toward a shared destination. That means setting a goal, believing in it, and not giving up.

We also need funding—beyond just dues, PMT, and Salmon Run. Those revenue streams barely cover our current operating budget. We'll need something extra: a commitment like the one our members made when they bought property and retired the debt in just two years. That extra funding could come from a trust, an endowment, wills, or required retirement distributions. I'm sure there are other options as well.

**Finally, we need a facility that supports growth** and community: ADA-compliant bathrooms, larger classrooms and training areas, and single-level access for all.

So I'll ask again: What is the future of the Radio Club of Tacoma?

**What is your vision, your goal, your objective?** This isn't about having a hundred different visions. It's about rallying around one.

Step up, bus driver. I'm ready. And the future is waiting.

*Mike Isakson W7XH, Vice President  
Guest Editorialist*

# HAM RADIO WORLD NEWS

Amateur radio events from *around the world*



Web

## OPPOSITION TO NEXTNAV AND AST SPACEMOBILE ENCROACHMENT ON AMATEUR RADIO SPECTRUM CONTINUES

Amateur radio operators and technology advocates are intensifying their resistance to spectrum reallocation proposals by NextNav, Inc. and AST SpaceMobile that threaten the integrity of the 902–928 MHz band—a critical resource for ham radio, LoRa-based networks, IoT devices, and emergency communications.

In September 2024, NextNav petitioned the FCC to reconfigure the Lower 900 MHz band—transferring roughly 15 MHz of shared, low-power unlicensed spectrum into exclusive full-power use. The proposal would grant NextNav a nationwide license to operate high-power 5G and terrestrial Positioning, Navigation & Timing (PNT) services, which the company frames as a GPS backup. Critics argue their analysis fails to account for the wide deployment of devices within the band and could decimate existing uses.

ARRL, the National Association for Amateur Radio, filed strong formal objections in late 2024 and renewed them in May 2025, warning that NextNav’s plan would introduce massive interference from multi-kilowatt signals to already struggling secondary users. ARRL urged protection of current amateur operations, particularly emergency mesh networks such as those built with AREDN software.

A coalition of consumer advocacy groups, technology organizations, and business interests—including the Open Technology Institute, Public Knowledge, Consumer Reports, and Next Century Cities—submitted joint comments in September 2024. They highlighted the economic dependence of smart-city infrastructure, industrial IoT, and wireless sensors on Part 15 devices operating in the band. They stressed that reallocating over 60% of this spectrum to a single for-profit licensee would severely disrupt millions of devices and innovation at large.

On the other hand, NextNav defends its petition, citing national security and public safety benefits of a terrestri-

al PNT complement to GPS, though opponents accuse the company of seeking a regulatory windfall under the guise of innovation.

While their direct relation to NextNav’s petition is less pronounced, AST SpaceMobile has also faced spectrum-related scrutiny—particularly regarding brighter-than-expected terrestrial uplinks and potential interference with existing UHF and astronomy operations. Amateur operators have monitored satellite Doppler signatures from BlueBird launches in bands that overlap amateur allocations.

Together, the pushback from ARRL, open-source communities such as Meshtastic and LoRa developers, and broader public-interest coalitions illustrates a growing consensus—preserve the 902–928 MHz band as open, shared spectrum or risk eroding decades of grassroots innovation and emergency resilience.

### Sources:

- <https://www.arrl.org/news/arrl-urges-protecting-the-amateur-radio-902-928-mhz-band>
- <https://www.arrl.org/news/arrl-defends-902-928-amateur-radio-band>
- <https://www.newamerica.org/oti/wireless-future-project/legislativeregulatory-filings/95-joint-comments-opposing-nextnavs-proposal-for-unjustified-swap-of-lower-900-mhz-band-spectrum>
- <https://www.communicationsdaily.com/article/2024/08/13/nextnavs-900-mhz-band-proposal-draws-quick-objections-from-amateur-radio-operators-2408120024>
- [https://en.wikipedia.org/wiki/AST\\_SpaceMobile](https://en.wikipedia.org/wiki/AST_SpaceMobile)

-Quoted from multiple sources

# ARRL NEWS & VIEWS



W1AW

## Safety Stand-Down: Look Up and Live

07/17/2025

By Sierra Harrop, *W5DX*

ARRL Public Relations and Outreach Manager

Electricity is a killer. About 150 people die each year at work from contact with electricity, according to the Electrical Safety Foundation International. Half of those are from contact with power lines. That data is just workplace deaths, so recreational and public service volunteering aren't even accounted for.

In a recent article, ARRL New Mexico Section Manager Bill Mader, K8TE, shared safety concerns and processes that can be implemented at ARRL Field Day sites. I'd like to share a simple phrase that may enhance your situational awareness: Look up and live.

"Look up and live" was drilled into me and every other television news employee who worked with electronic news gathering vehicles that had a pneumatic mast or satellite dish. It was the title of an industry-standard safety video published by the National Press Photographers Association.

In TV news, where I spent the first two decades of my professional career, there was always a deadline and often a tremendous sense of urgency at the scene of breaking news to get a live shot up first. Before the days of bonded cellular internet streaming, we used radio – microwave and satellite – to take viewers to the scene.

No matter the pressure from news managers, safety was paramount. When we approached a scene, we made sure to park the live truck at least 10 feet away from overhead wires to comply with regulations. My personal minimum was two truck-lengths from any lines, ideally a whole mast-length. If I had a 58-foot mast, I'd try to park at least 58 feet away from the nearest power line.

Identifying overhead lines was ritualistic: As I arrived, I got out of the vehicle, walked 20 feet away, looked up and walked around the entire perimeter of the truck while deliberately searching for overhead lines and obstructions. This additional 45-second process could feel like an eternity when news was unfolding dramatically for me to capture and report – but I couldn't go live if I was dead.

In pursuit of our amateur radio hobby, we should apply even more diligence. There's no pressure to get on for a ham radio activation. Take your time, walk around, be diligent. Look up and live.

Portable masts, vertical antennas, wire antennas slung up into a tree – anything you put up can become energized if it contacts an overhead wire. Do not take chances. Even what appears to be a phone or fiber line could be carrying lethal voltages. Do not become the path to ground.

One additional tip that I hope never applies to a radio amateur: Should a vehicle you're in become energized by a fallen line or a mast erected into power lines, do not leave it unless it is on fire. Call for help via phone or ham radio. Yell at any bystanders to not approach your vehicle. Electricity spreads out from a path to ground in concentric rings of decreasing voltage. Being in contact with different voltages is what will kill you. If a fire requires you to exit, carefully jump clear of the vehicle so as to not contact the vehicle and ground simultaneously. Be mindful of your movements: "Bunny hop" with your feet together or shuffle your feet on the ground in small increments without lifting either of them. Do not provide a path between the different potentials by walking normally or by falling and catching yourself with your hands.

Please be careful when erecting portable gear within the wires environment. **Remember: Look up and live.**

■ -Sierra Harrop, *W5DX*





**What a kind and amazing surprise from our first club member outside of the United States**, Pascal Carré F4LPH from Ballan-Miré, France, who so kindly sent the club a wonderful travel magazine Loire Valley Châteaux, along with a couple of his QSL cards and sticker for the Réseau des Emetteurs Français, the French equivalent of the ARRL.

Quoting Pascal, *"I just signed up for your radio club because I really appreciate the work you do there, especially with your digital newsletter."*

*I'm sending you a magazine featuring my region so that radio club members can discover the Loire Valley Châteaux.*

*By the way, if any of you are coming to my area, please don't hesitate to contact me. My wife and I would be delighted to welcome you".* [full text in yellow sidebar to the right].

And likewise, Pascal, the same holds true for the Radio Club of Tacoma, and for myself personally—if you're ever near Seattle please don't hesitate to let us know.

Thanks so much for this very kind gift and surprise. Members: these materials are available in the Club Secretary's locked cabinet in the Oakman Library—see Secretary Gary for access on any Open House Saturday.

On behalf of the entire club, merci beaucoup mon ami.

-Dave W7UUU, Editor, *The Logger's Bark*

Hello Tacoma Radio Club,

I just signed up for your radio club because I really appreciate the work you do there, especially with your digital newsletter.

I'm sending you a magazine featuring my region so that radio club members can discover the Loire Valley châteaux.

By the way, if any of you are coming to my area, please don't hesitate to contact me. My wife and I would be delighted to welcome you.

Otherwise, I hope to contact you one Sunday evening on 28.375 MHz. For your information, I also host a local QSO every Sunday from 6:00 PM to 6:30 PM (4:00 PM ZULU) on 28.337 for OMs in my department (37) and from 6:30 PM to 6:45 PM on 27.375 SSB for unlicensed OMs.

See you soon on air  
73's to all radio club members

Pascal - F4LPH

Manager from Repeater F6ZBO <https://sites.google.com/view/f6zbo/accueil>

All photos this page: Dave W7UUU

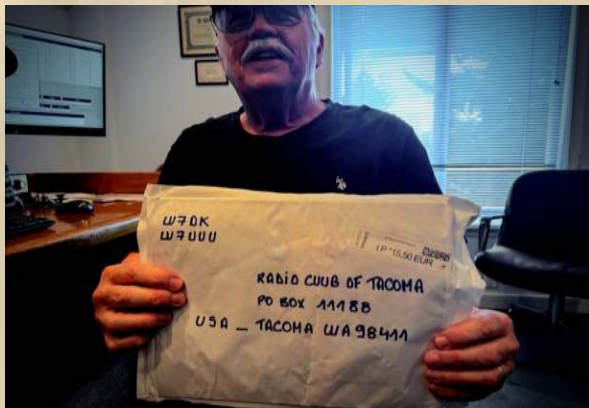

Club Secretary Gary W7GX awaited my arrival at the Clubhouse to open the mystery package from far-away France!





**Hi Dave,**

I really enjoyed your piece on Art Bell in the June issue of *The Loggers Bark*.

I too had a long ride home after working the second shift at a TV station. I began cruising the late night AM band to break the boredom and that is when I first heard Art Bell's show, Coast to Coast AM. He always made the show entertaining.

I'm retired from the business now but your piece brought back some great memories of late night AM.

73—Joe Molon, **KA1PPV**

**Dear Joe,**

*Thanks so much for the reply and the similar memories to mine. Art was truly one of a kind.*

-73 Dave **W7UUU**

**From QRZ,**

Another GREAT issue of the *Logger's Bark*. I really look forward to every issue. SOOOO much interesting material in every issue. The 'ham-standard' of club newsletters. Keep up the fantastic work! - Tom **K8UUZ**, Mantua, OH

**Dear Tom,**

*Thanks so much for the kind words and for taking the time to read *The Logger's Bark*.*

-73 Dave **W7UUU**

**From QRZ,**

Wow Dave! This is the first time I looked through one of these -- what a work of art!

I have to say, I couldn't help but notice that you tried really hard to represent the ladies. I found that touching. Great work overall, very impressive.

-Mindy **KM1NDY**

South Boston, MA

**Thanks Mindy,**

*I appreciate the kind words. Yes, I make a focused effort every month to represent the members in the broadest sense possible. I take 95% of the photos (and I write virtually all of the technical articles) so I'm very immersed in the publication at all levels to produce the highest quality I can.*

-73 Dave **W7UUU**

**Hi Dave,**

Besides the actual content of each issue, which is impressive, what are the tools used to create the issue? I'm assuming this is not all done using MS word... what is your publishing workbench? Just curious...

73—Rob **KA2CZU**

Smithville, NJ

**Dear Rob,**

*Great question—one I'm thinking others probably want to know as well. The platform I use for *The Logger's Bark* is simply MS Publisher as found in the Office 365 suite. Many of the articles I write and those of most submissions are done in MS Word just for convenience. Word easily migrates into Publisher. But all of the page layout and everything that goes with that is all done in Publisher. Images are handled using Adobe Photoshop Elements as well as an online subscription called Fotor Pro that I use for a number of graphical manipulations. Final output is simply a PDF export from within Publisher.*

-73 Dave **W7UUU**



Photo: **WW7LW**, Mount Rainier Amateur Radio club during Field Day, 2025. Class 1D, Section: ID (Idaho)

Photo provided by: Rich **KR7W**

**Dear Editor,**

Please see the attached photo. This is **KR7W's** first Field Day operating Class 1D from home.

In total I made 155 CW Qs and 1 SSB Q. Bands were 20 and 40 meters, about 50% on each band.

BIC ("Butt in Chair) time was 4 to 4.45 hours—about the same amount of time that I would operate at pre-Covid W7DK's Field Day events.

The rig is an Icom IC-7700 running 90 watts to either a 20/40-meter Fan Dipole in the house attic or a 40-meter NVIS antenna at 5 feet elevation in the back yard. On 40, the rig would transmit on the attic antenna and receive on the NVIS. This really improved the signal to noise ratio to combat the high amount of man-made noise in this neighborhood.

Propagation seemed poor. Approximately 80% of the QSOs made had a receive S-meter reading of S1 or lower. Reverse Beacon Networks showed many hits on CQs called. Overall I am pleased with my 2025 Field Day experience.

-Rich **KR7W**  
Idaho Falls, ID

# THE MAILBAG

LETTERS  
To The Editor

W7UUU

## POETS RETREAT



HERE I SIT, ALL BROKEN HEARTED  
TURNED ON MY RIG, BUT THE FUSE  
DEPARTED  
IT WENT WHERE ALL DEAD FUSES GO,  
TO THE HUNTING GROUNDS OF THE SHOT  
SLO-BLO

IT WAS THE LAST, AS LUCK WOULD BEAR  
NOW HOW DO I GET ON THE AIR.  
THE TINFOIL IS HANDY, SO HERE IT GOES  
I TURNED ON THE SWITCH AND THE BLUE  
SMOKE AROSE.

THE SPARKS DID FLY, THE TRANSFORMER  
WENT  
THE AIR FILLED WITH A BURNING SCENT  
I SHUT THE RIG OFF BUT THE DAMAGE  
WAS DONE.  
I SWORE LIKE A TROOPER AND A  
SON-OF-A-GUN

THE MORAL OF THIS STORY GOES  
THAT TINFOIL MAKES DARNED POOR  
SLO-BLOS  
LEAVE THE RIG OFF AND JUST RETIRE  
UNTIL A NEW FUSE, YOU CAN ACQUIRE.  
...K7GPK

Submitted by Mike **W7XH**

From the April, 1964 W7DK Logger's  
Bark newsletter. Poem written by  
Emil Koth **K7GPK(SK)**, member #427

Click [HERE](#) to view online.

## From QRZ,

Good job and of course always what  
a ham operator wants to read. The  
specials on QRP rigs are brilliant this  
time as well as before. It's also good  
to spread the news about open  
source software, like JS8Call... it's so  
necessary today to do that.

-Cornelius **DO1FER**  
Braunschweig, Germany

## From QRZ,

Simply amazing! I am honored to be  
a member of this club!

-BJ **KO7T**

## From QRZ,

Wowsers, Dave. Another hit out of  
the park! Thanks for all your hard  
work. Another great issue.

-Gary **WG7X**

Secretary, Radio Club of Tacoma

**BJ & Gary**—thanks much for the kind  
words and back atcha for all you  
guys do for the club as well.

-73 Dave **W7UUU**

## From QRZ,

[Google translate from French]

Hello and thank you very much! The  
heatwave (40°C, 104°F) means I have  
some reading to do, as I can't stay in  
my room with the radio on, but I'll  
be able to read!

Best regards to you

-Pascal **F4LPH**

Ballan-Miré, France

## Dear Pascal,

Wow! 40°C is indeed HOT! I want to  
thank you very much for the wonder-  
ful package of "local flavor" of your

region in France. That was very nice  
of you! -Dave **W7UUU**

## From QRZ,

This edition of The Logger's Bark is  
the Cat's Meow! (I bet you've not  
heard that saying since 1968!). I am  
not even halfway through the maga-  
zine yet. Now you force me to order  
that neat little receiver featured in  
The Frugal Ham!

-Ronnie **NZ4X**

Naples, Florida

Thanks as always, Ronnie, for the  
kind words!

-73 Dave **W7UUU**



# W7DK LOGGER'S CERTIFICATE

## Classic "first award" for Members



**HAVE YOU APPLIED** for your own W7DK Logger's Certificate?! It's FREE and it's EASY! All you have to do is work at least 10 members of the Radio Club of Tacoma, then send in your list of call signs worked, and BAM! We'll print out your certificate and get it to you toot sweet by US Mail.

series of recipe boxes still held by the club. We still have a huge stash of this beautiful OFFICIAL logger's Certificate paper.... So if you do not already have yours, just shoot us an email with your list of call signs worked, and put "Logger's Certificate" in the subject line... **-editor**



**There are no confirmations required, no logs to submit,** and really no rules other than the call signs you

submit must be

members of the club. You may work them on HF, 2m FM, on FT8 or SSB or any other mode! In fact, one of the best ways to get your 10 contacts is to check into the weekly Tuesday Night Net on the 147.28 club repeater... every Tuesday at 7:30 PM.

This venerable award was first launched in 1957, using certificate paper printed by club member Dick Ryan, **W7RGD** using a donated printing setup.

As of the date of this publication, there have been almost 700 certificates issued, including a few reissues over the years to replace lost certificates.

The original certificates were hand-lettered by long-time RCT member Barbara Osborne, **W7UYL** (SK 2022), and all of the records were kept in a

Barbara Osborne  
**W7UYL** in 1955  
an  
RCT USO event



Our FIRST EVER DX certificate!  
#698 goes to Phil Hardstaff **C21TS** in far-off [Nauru](#) in the South Pacific!

**Wanna get yours? Send in those contacts!**

# W7DK LOGGER'S CERTIFICATE

**SEARCH YOUR LOGS!!! GET YOUR CERTIFICATE!**



THE W7DK RADIO CLUB OF TACOMA LOGGER'S CERTIFICATE is available to anyone anywhere who has worked at least 10 members of the club. It's a long-held club tradition to issue these certificates, with just shy of 700 having been produced since the start of the program in 1957.

Are you active on the HF bands? If you are, it's entirely possible you already have all the contacts you need to get your own Logger's Certificate! And it's really easy to search this.

Almost all modern computer logging systems have a way to search for the county of stations you have worked. For example, in the popular N3FJP Amateur Contact Log (ACL), to find stations that could possibly be W7DK members, just go to the "County" field in the ACL interface, then click "Search". If you have at least 10 results come back, send me the list and I will check to see how many are members!

For those who use QRZ's powerful logbook software, just open your main logbook, click the pulldown menu for "Filter" and select "New". In the "Filter Name" box you could call it "Logger's Certificate" (and then "save" if you want to use this rule in the future) - then in "Select Field" select "Their County", then for "State" pick WA for Washington, and lastly "Compare Value" set to "Pierce County, WA". Lastly, click "Add Rule". Once you do this, you will now see only those logged QSOs that the other station reported Pierce County. Since the Radio Club of Tacoma is in that county, your likelihood of pulling up club members is very high.

Regardless of the logging software you use, most should have a means for searching out county information.

Just note that if you find "Special Event" call signs such as W7F, W7B, etc., those don't count as multiple operators share those call signs during the club's Bigfoot event every October. Only actual FCC-assigned call signs count for the Logger's Certificate. The club call of W7DK or the museum call of W7OS are considered acceptable to use.

Also consider filtering for Kitsap County (where I live) as we have a number of members there. You could also include King County, but I warn you: it's the largest county in the state, and has a lot of hams—most of whom will not be W7DK members. Searching there will result in a huge list without many "hits".

**Wanna get yours? Send in those contacts!**

Then just email me the list of calls—you don't need to include anything else: it's the Honor System. I won't be confirming anything other than if the call sign is (or ever was) a member of the club.

So start SEARCHING! I will send you your own beautiful Logger's Certificate free of charge—mailed to your listed QRZ mailing address. In return, just send me a photo of you holding your certificate and I will run that in a future issue of The Logger's Bark!

-Dave W7UUU



Above: Custom Filter dialog for QRZ Logbook—just search for State=WA, and Value=Pierce (or Kitsap) County

N3FJP's Amateur Contact Log 7.0.11

Rec#	Call	Date / Time	Band	Mode	Power	Snt	Rec
23688	NASH	2024/02/14 01:08	20	CW			
23685	OMDM	2024/02/18 02:00	20	CW			
23684	OM5R	2024/02/18 01:55	20	CW			
23683	PV8Y	2024/02/18 01:42	20	CW			
23682	SA1P	2024/02/18 18:35	15	CW			
23681	SZVY	2024/02/18 17:47	10	CW			
23680	EDTW	2024/02/18 18:00	10	CW			
23679	PR1T	2024/02/18 17:49	10	CW			
23678	PV4W	2024/02/18 17:41	10	CW			
23677	SG7T	2024/02/18 18:18	15	CW			
23676	SH8K	2024/02/18 18:23	15	CW			
23675	IO4K	2024/02/18 19:29	15	CW			
23674	OL3Z	2024/02/18 19:27	15	CW			
23673	TM9C	2024/02/18 19:27	15	CW			
23672	EA2KV	2024/02/18 22:09	20	CW			
23671	EDTW	2024/02/18 22:21	20	CW			
23670	ED8M	2024/02/18 20:24	15	CW			

Ready to begin!

Call	Date	Band	Mode
Name	State	County	Frequency

Left: Using N3FJP Amateur Contact Log, simply enter Pierce (or Kitsap) for the County field, then click "Search" to see a list of calls from these counties

# MEMBER SPOTLIGHT?



Chip Margelli K7VPF (K7JA) SK

Chip Margelli was ten years my senior but I knew him well during my years with the Radio Club in the mid/late 1970s. He was an amazing character and person... with a very strong admiration for the club, and especially for CW. In late 1978 Chip moved to Tokyo to serve as Assistant to the President of the Yaesu Company, after which he moved back to the U.S. to Los Angeles, as a Yaesu U.S. rep. He also worked at Ham Radio Outlet as an IT specialist. Chips family was a long-time club family starting with his grandpa Hunt Mitchell (**WA7AKW(SK)**) who served as RCT club treasurer. Chip's wife Janet **KL7MF** served for a time as RCT Club Secretary. Chip was directly involved in the installation of the club's current main tower and was a very active participant in the club's Field Day Efforts (his slogan back then, when W7DK considered Field Day to be competitive, was to "Keep the Rate Up"). Chip became world-famous on the Jay Leno show ([LINK](#)) demonstrating Morse via CW to be more efficient than texting! Very sadly, Chip died suddenly in May of 2023 at age 72—and will be missed by those of us who knew him well.

# ASK ELMER!



Mystery Elmer

Dear Mr. Elmer,

I'm still pretty new to ham radio. I got my General class license about a year ago, and I just started using HF with my new Icom IC-7300. I put up a G5RV antenna between two tall trees at the corners of our house, probably around 45 feet up. It runs right over the roof, and the feedline comes into a spare bedroom where I set up my little radio space. I'm just using SSB for now and don't have an amplifier nor do I plan to add one. I only use 40, 20, and sometimes 12 meters (my antenna won't tune on any other bands).

My wife is a bit worried about the antenna being directly over the house. She's concerned that the radio waves might be harmful — to her, the kids, or even me. I know there's supposed to be some kind of online calculator to check if it's safe, but I don't really understand how to use it or what info I need to plug in.

Is this something you can answer?

Dying to Know if I'm Safe

Dear Dying,

First off, you are right to ask! RF exposure has been identified for years as potentially harmful to humans who are in the direct field of any sort of radio energy. And you're also right there are online calculators for determining if you are safe.

The one I like is here at this link: <https://www.arrl.org/rf-exposure-calculator>

So let's just plug in your numbers and see what we get. A G5RV antenna in general is considered to be a 1 dBi gain antenna on 40 and 12, but it was designed to give about 2.2 dB gain on 20 so we'll check all the bands.

Then, we'll use your SSB operation from a 100w transceiver and assume 100% of that power reaches the antenna (which isn't likely but go with it). That mode is considered

to be a 20% duty cycle (with no speech processor). But it could be pushed to 50% with a ton of processing so we'll assume worst case and assume you're using a lot of speech processing. The rest of the parameters you can view in the calculator results screen capture.

The good news is that on 40m, the minimum safe distance from the antenna is just over 1 foot; on 20-meters with the higher gain, that distance goes up to 2.57 feet; and on the highest frequency at 1 dB gain, 12-meters is 3.83 feet. This means that given your stated antenna height, there's no way that anyone in your home would be at risk for the power level, mode, and antenna type as you've described it.

Of course, this is something of a simplification—you should read the full instructions at this link: <https://www.arrl.org/rf-exposure-calc-instructions>. But suffice to say, unless your family climbs those trees, you should be just fine.

Click the image below to go to the Calculator.

-Mystery Elmer #4

**This calculator should not be used for antennas that are less than 20 cm (8 in) from a person.**

View detailed instructions for each parameter. (opens in new tab/window)

Parameters

- Power at Antenna: (Need help with this?) 100 (watts)
- Mode duty cycle: Conversational SSB, heavy speech processing (duty cycle=50%)
- Transmit duty cycle: (time transmitting) You transmit for 5 minutes then receive for 10 minutes (and repeat).
- Antenna Gain (dBi): (Need help with this?) 2.2
- Operating Frequency (MHz): 14

Include Effects of Ground Reflections

Calculate

**This calculator should not be used for antennas that are less than 20 cm (8 in) from a person.**

Results for a controlled environment:

Maximum Allowed Power Density (mW/cm<sup>2</sup>): 4.5918  
 Minimum Compliance Distance (feet): 1.8172  
 Minimum Compliance Distance (meters): 0.5539

For an uncontrolled environment:

Maximum Allowed Power Density (mW/cm<sup>2</sup>): 0.9184  
 Minimum Compliance Distance (feet): 2.5699  
 Minimum Compliance Distance (meters): 0.7833

Print Results

Calculator results for 14 MHz (20m) & 2.2 dB gain

# THIS MONTH'S CALENDAR



W7DK

July		August, 2025				September	
Sunday	Monday	Tuesday	Wednesday	Thursday	Friday	Saturday	
31 July	July	July	July	July	1	2 10:00am Open House	
3	4	5 07:30pm 2 Meter Net 147 ...	6 07:00pm Board meeting	7 06:00pm HF Night at the ...	8	9 10:00am Open House 01:00pm General meeting ...	
10 12:00pm Kirkreit Summer ...	11	12 07:00pm VE License Exam ... 07:30pm 2 Meter Net	13	14 06:00pm HF Night at the ...	15	16 10:00am Open House	
17	18	19 07:30pm 2 Meter Net 147 ...	20	21 06:00pm HF Night at the ...	22	23 10:00am Open House	
24	25	26 07:30pm 2 Meter Net 147 ...	27	28 06:00pm HF Night at the ...	29	30 10:00am Open House	
31	September	September	September	September	September	September	

Click map to view on [W7DK.org](http://W7DK.org) with current active links!

## Did You Know??

August got its name in the year 8 BC when the Roman Senate honored Emperor Augustus Caesar by renaming the month Sextilis, which was originally the sixth month of the early Roman calendar. Augustus chose this month because it marked several of his major triumphs, including the conquest of Egypt. Interestingly, although February had fewer days, a day was added to August to make it as long as July—named for Julius Caesar—so that Augustus wouldn't have a shorter month than his predecessor. The month of August once had its own constellation: [Antinous](#), named by Emperor Hadrian after his beloved companion who drowned in the Nile in October 130 CE. Hadrian declared **Antinous** a god and created the constellation just south of Aquila. Though it appeared on star charts for centuries, it was eventually dropped from official astronomical catalogs in the 20th century.



**IN 1966 MARGIE CHAVIS, K7AMJ (SK)**

put together a wonderful

**50th Anniversary**

scrapbook of W7DK club news clippings, notable events, photos, etc. This monthly column will run for just a few issues, and feature selected items from the scrapbook just for a glimpse into the club's past. Even those readers who are not a member will still find enjoyment in reading about historical ham radio tidbits from more than half a century ago.

—editor

**THREE TIMES IN THE 1930s** the Radio Club of Tacoma hosted the ARRL Northwestern convention. Today, this event is held in Seaside, Oregon at a massive amateur radio gathering called Sea-Pac—an event most hams in the Pacific Northwest are aware of. It's a major happening and always has been.

The first time it was hosted by the Tacoma club was 94 years ago this month, on August 29th and 30th, 1931. The venue was The Tacoma Hotel in downtown Tacoma, considered at the time to be the "[grandest hotel in the Northwest](#)".

While no records were held by the Radio Club that would indicate how many amateur radio attendees there were, the formal portrait of the ARRL and RCT contingent suggests this was a very large and well-attended event.

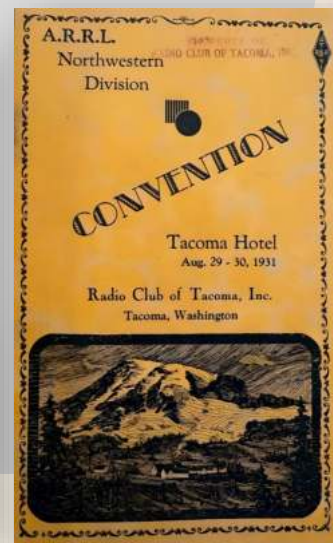



Larger view of the ARRL gathering at the 1931, possibly taken at Point Defiance Park in North Tacoma. While hard to read, a few call signs are visible. Click the image to see the full scan that can be zoomed for better viewing.

It's impressive that the Radio Club of Tacoma was the host not just once, but three times for this massive event.

-Dave **W7UUU**

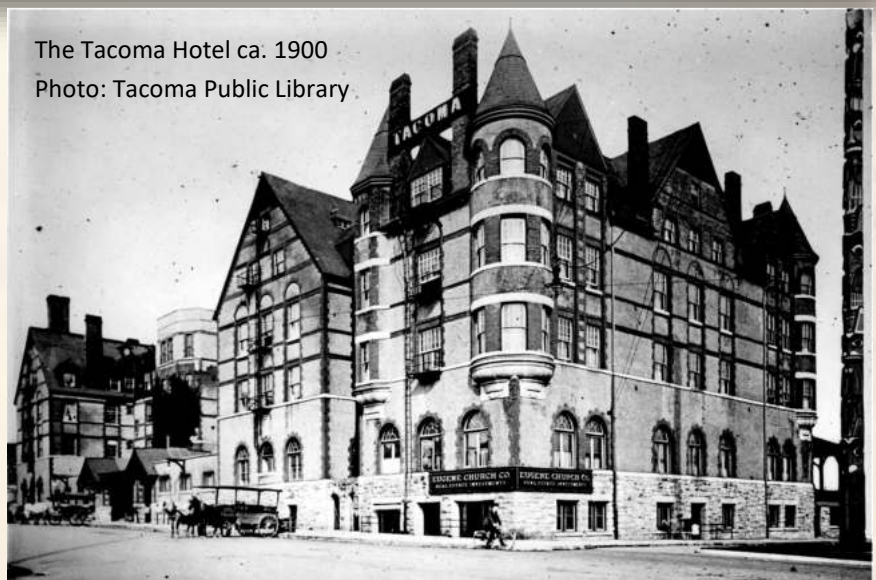



It's that time again!

# W7DK Summer Picnic 2025!

**Sunday August 10th 11-3  
 Fort Steilacoom Park  
 8714 87th Ave. SW  
 Lakewood, WA 98498  
 Shelter #1**



**Picnic Shelter #1**



**Chef Paul W7PFU**

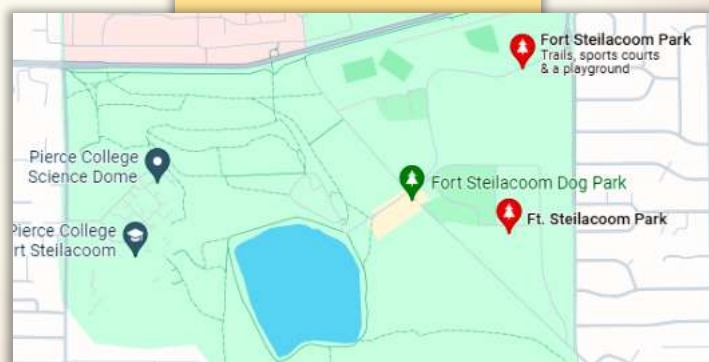

Click either photo or the map for a Google Maps view

It's this month, folks!... the 2025 W7DK Summer Picnic will be held on Sunday August 10th, in the same location we have used for the last few years.

Just enter the park from the North, off Steilacoom Blvd. SW (right across from Western State Hospital). Turn right into the park on Dresden Ln. SW. Follow the road around and you'll see a large kids play area. You can park there in the large lot, or continue on around on the road, going past the red barns—there's an access road to the rear parking lot behind the picnic grounds.

As always, the Club will provide burgers, hotdogs, and beverages. Please bring a potluck dish of your choice.

As in years past, we will also play a couple rounds of Radio Bingo, or "RINGO" as we call it!

And of course, no alcohol, smoking, or vaping is allowed anywhere inside the park.

Hopefully the weather will favor us this time—the last few years it's been chilly and gray. Maybe this year will be different! See you there!

■ -editor

# AROUND THE CLUBHOUSE

But first.... A little *about* the Clubhouse



W7DK

**THE RADIO CLUB OF TACOMA IS UNIQUE** not only in its age (continuously operating since October 1916) but also in its ownership of an actual clubhouse and adjacent parking lot. The current clubhouse was purchased by members in 1957 (the previous clubhouse was purchased in 1927!) and has been maintained on this site ever since. But it takes time, talent, and treasure to keep this dream a reality. Club membership is one of the solid ongoing means with which the club maintains not only members to help with the upkeep, but to also raise the capital that's required to keep our clubhouse in tip-top shape.

If you are not yet a member, please consider joining—even if you're not local! If you enjoy reading The Logger's Bark from afar, you can be a part of our club just as if you were here. And if you are a local, please consider contributing your own skills and effort to keep this club the wonderful thing it is. Ask any officer how you can help. Thanks to all our loyal members! -Dave W7UUU

**JOIN NOW!**



Photos on left from RCT Archives—photos on Right by Dave W7UUU

# AROUND THE CLUBHOUSE

## Recent Photo highlights from the Clubhouse



*WB7QAG (not to be confused with Jeff KB7QAG!) left visits with Leah K7IPT and Mike W7XH in the kitchen*

*“Membership Mike” W7XH gearing up to do some membership activity in the Oakman Library room*



*Anne N7ANN (assistant Bark editor) and Mike W7XTZ show off the current Logger’s Bark printed edition in the clubhouse classroom*

*Tim KF4EDG stops by to visit the HF room—he emailed later to say he not only passed General but went on to pass Extra on July 8th! “Now this is news that’s ‘Extra-Extra’” he said—congratulations!*

**Got pictures from the clubhouse? Send ‘em in!**

*All photos this page provided by Dave W7UUU*

# AROUND THE CLUBHOUSE

## Recent Photo highlights from the Clubhouse



W7DK



Bob **K7MXE** shows off the July 2025 "Field Day" in review edition of *The Bark*



Walt **WA7SDY** gears up for the Saturday Noontime Net on 40-meters



Paul **N7OSS** and President Adam **W2NCC** check out the clubhouse gutters for the possibility of a "gutter antenna" just for the fun of it!



Anne **N7ANN** visits with Eric **WB7QAG** in the clubhouse kitchen

**Got pictures from the clubhouse? Send 'em in!**

All photos this page provided by Dave **W7UUU**

# AROUND THE CLUBHOUSE

## Recent Photo highlights from the Clubhouse



W7DK



*The old and the young! We host them all!  
Bob **K7MXE** with Max **KK7HAY** in the Classroom*



*Club Secretary Gary **WG7X** at the Icom IC-7610  
station upstairs in the HF Room*



*President Adam **W2NCC** talks policy with Paul **N7OSS**  
in the clubhouse kitchen on a recent Saturday*



*Mike **W7XH** catches up with Paul **N7OSS***

**Got pictures from the clubhouse? Send 'em in!**

*All photos this page provided by  
Dave **W7UUU***

# AROUND THE CLUBHOUSE

Recent Photo highlights from the Clubhouse



W7DK



*Jon AI7WP stopped in to pay a visit in the HF Room and W7OS Museum*



*Bob K7MXE discusses the "GMRS gateway into amateur radio" with President Adam W2NCC*



*Mike W7XTZ catching up on signing DK Membership certificates*

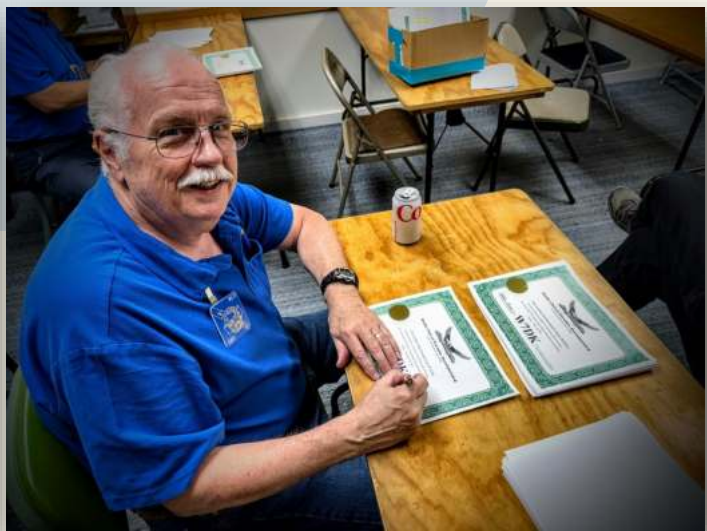

*Gary WG7X pitches in to help out*

**Got pictures from the clubhouse? Send 'em in!**

*All photos this page provided by Dave W7UUU*

# AROUND THE CLUBHOUSE

## Recent Photo highlights from the Clubhouse



W7DK



John **K2CCT** kicking back in the HF room



The Gang's All Here!  
(L>R: Nolan **K7GBM**, David **AC7KP**, Phil **K7PIA**,  
and Paul **W7PFU**)



Nice tidy repair desk in the W7OS museum



Hallicrafters SX-101A in the midst of a needed  
recap and realignment by Dan **KD7SV**

Got pictures from the clubhouse? Send 'em in!

All photos this page provided by  
Dave **W7UUU**

# AROUND THE CLUBHOUSE

Recent Photo highlights from the Clubhouse



W7DK



*Nolan **K7GBM** finishing off a donut and visiting!*



*Jeff **W8NGS** sorting through a recent donation*



*Anne **N7ANN** taking some time to hang in the Classroom*



*Paul **N7OSS** and Gary **WG7X** review Membership certificates*

**Got pictures from the clubhouse? Send 'em in!**

*All photos this page provided by  
Dave **W7UUU***

# AROUND THE CLUBHOUSE

## Recent Photo highlights from the Clubhouse



W7DK



Always with a smile—Mike **W7MKE**



Bob **K7MXE** chats antennas with Jeff **W8NGS**



Chatting it up in the Lou Room

L>R: Scott **KA7IOX**, Phil **KC7PS**, Stephen **AD7AB**, and Bob **K7MXE**



Mike **W7MKE** and Walt **WA7SDY** work out settings on the FT-847

Got pictures from the clubhouse? Send 'em in!

All photos this page provided by Dave **W7UUU**

# HAM'S HELPING HAMS

## Helping out at Another Ham's QTH



W7DK



An **N7OMS** and Bob **AD7LJ** work to free the BigIR vertical that came apart in a windstorm at Anna **K7ANA**'s place in Tacoma



Once on the ground, it was easy enough to re-attach the fiberglass tubing sections and cinch them down again, ready to re-erect the vertical



Gary **WG7X** (rear, hidden), Bob **AD7LJ** and Al **N7OMS** gear up to reinsert the mast into the mount. Fortunately, the SteppIR tape was fully retracted before the storm



Sweet success! The BigIR is back on its base...  
Bob **AD7LJ**, Gary **WG7X**, Anna **K7ANA**, and Al **N7OMS**. Temperature was about 95 degrees today!

**Got pictures from the clubhouse? Send 'em in!**

All photos this page provided by  
Dave **W7UUU**

# AROUND THE CLUBHOUSE

## Recent Photo highlights from the Clubhouse



W7DK



August Birthdays!!

Call Sign	Name
AB7DG	Doug Schafer
AC9OX	Larry McElhiney
AD7VL	Steve Blacksten
AI7WP	Jon Bly
AJ7MH	Mike Hancock
K0GRE	Stanislas Bach
K7APO	Erick Jenkins
K7CBE	Chuck Eyres
K7DBU	Jack Hegseth
K8IG	Frederick Freer
KD4VOM	Larry Watson
KD7QBE	George Lightner
KD7RAE	Vincent Stoneking
KD7WLR	Larry Vogel
KE7YOB	Douglas Schell
KF7PXB	Joe Winkler
KF7TEW	Dick Heggen
KF7UFR	Warren McPherson
KF7ZFL	Leo Smith
KG7QXK	Robert Brown
KI7QI	Bob Cowan
KI7VXX	Ryan McKenna
KJ7CEZ	Aaron Grenlund
KJ7CFF	Michael Grubiak
KK7SSH	Alan Scott
KK7VH	Rich Heasty
KK7YTU	Elliott Brighton
KK7ZGJ	Megan Tuche
KN6OFF	George Robinson
N7HT	Megan Tuche
N7QOZ	Bob Crelling
WX4C	Donald Landes



Doug AB7DG—Happy Birthday!



Steve AD7VL—Happy Birthday!

photos by Dave W7UUU



# CLUB ACTIVITIES

## Thursday HF & Activity Nights

**MOST EVERY THURSDAY EVENING** from 6PM until 9PM, the Radio Club of Tacoma opens the HF room for one-on-one training time. Saturdays are a great time to come see the clubhouse and socialize, but often it's tough to get "quality time" with the radios. This weekly event is open to all—members and non-members alike. There is always at least one Extra Class operator on hand with a solid knowledge of the Icom and Flex radios in use, as well as the antenna patch bay, amplifiers, and tuners. Even non-licensed "hams to be" can take a hand operating under the tutelage and watchful eye of an experienced "Elmer" on hand to show the ropes. Other nights, the club takes on build-it projects in the classroom—Come on by any Thursday!

■ *-editor*



John **K2CCT**, a recently renewed RCT member, stopped by to get ideas on how to do FT8 with his older Yaesu FTDX-5000 transceiver

Photo by Mike **W7MKE**



Mike **W7MKE** & Julie **W7JUL** building antennas

Photo by Gary **WG7X**



Lee **KF4EDG** (left) & Jeff **W8NGS**  
fixing radios in the RF Lab

Photo by Gary **WG7X**

# CLUB ACTIVITIES

## Thursday HF Nights, RCT Yard Upkeep

THE RADIO CLUB OF TACOMA INC



*On a recent Thursday HF night, Phil **K7PIA** spends some time working out the contesting schedule for the HF Committee*



*Julie **W7JUL** and daughter Molly help chop up and load trimmings from the club trees*



*Pruning job well done!*



*All photos this page provided by Mike **W7MKE***



## Open House Reminder!

**THIS IS JUST A WELCOMING & REMINDER** that the W7DK Radio Club of Tacoma Clubhouse holds an open house on most Saturdays of the year (click [HERE](#) for exclusions) from 10:00 AM to 2:00 PM. There’s always a nice group of members but ALL visitors interested in amateur radio are welcome to stop by! You do not have to be a member or even a ham to visit us. Please be sure to sign the Visitor’s Logbook in the kitchen, say hello to your Clubhouse Host, have a cup of coffee and a donut (always a nice assortment on hand). You may wander the building—visiting the classroom, the downstairs “shack parlor” we call The Lou Room, and of course upstairs to see the main HF room and the [W7OS Doc Spike Memorial museum](#)—a living collection of vintage gear that regularly gets on the air.

The last Saturday of every month, we hold a mini flea market where members can sell their ham gear. But even non-members are eligible to dicker for deals and take home gear. And starting around 11:30, our club Chef Paul **W7PFU** serves up free chilidogs, or sometimes burgers or spaghetti at the chef’s whim. We hope to see you stop by soon!

■ -editor

## Mini-Swap Meet Monthly

**DO YOU HAVE EXCESS GEAR TO SELL?** Members of The Radio Club of Tacoma have a little perk every month with our own mini Swapmeet held in the clubhouse on the last Saturday of each month. No charge for a table—just bring your wares and set up shop! Non-members and visitors are free to stop by and see if they can pick up bargains. The club also has gear donated regularly that is made available to visitors and members alike, available for purchase via donation. And of course, as mentioned in the Open House reminder, the club chef Paul **W7PFU** cooks up chilidogs or spaghetti (whatever suits his mood!) at no charge for guests. ■ -editor





## How To Lock The Doors

**AS WAS REPORTED** in last month's Bark by our club Secretary, Gary **WG7X**, in recent months there have been reports of the clubhouse being found unattended and the doors not even locked! Obviously, this is not acceptable. It's the responsibility of the Club Hosts on Open House Day (Saturday) or those who have door and alarm codes on other days to make certain the building is secure when leaving.

**But should you be in the position of being the "last one out", you can still LOCK THE DOOR** even if you don't have the code or a key. Simply pull the door closed and push the "lock symbol". The battery-powered mechanism will then lock the door (you won't be able to get back in without the code!). This applies to both the front door and the back door. See photo below—note the "lock" button.

-Dave **W7UUU**



## Help Keep The Clubhouse Clean

**THIS IS JUST A GENTLE REMINDER** that the W7DK Clubhouse is for all members to use and enjoy, and is a place to put our best foot forward as a club for visitors we welcome in almost every Saturday of the year.

Please be mindful of leaving trash, empty cans or bottles, food wrappers, McDonalds bags, and whatever else. Same holds for coffee cups... we frequently see cups left on classroom tables, the kitchen counters, at the Lou Room table, and wherever else. Please just make sure to "pick up after yourself". Also, remember that liquids and radios don't mix. Please don't take cans or cups of beverages into the HF room or the Museum—just water bottles with lids or closures of some sort. And no "sticky foods" like donuts! No one wants to reach for the tuning knob only to find your sticky donut residue on it!



# Bob K7MXE Club GMRS Repeater Build—but why?!

By Bob K7MXE



*[Editor's note: At the July General Meeting, our presenter was John Beaston K7TY who gave a great presentation on integrating GMRS radio into the club to help spur growth in ham radio. But prior to this presentation, Bob K7MXE was already thinking along those lines and took on the project of designing and building a complete licensed GMRS repeater for that very purpose. Bob wrote this article to document his work. -Dave W7UUU, editor]*

## I WANTED TO BUILD A GMRS REPEATER FOR USE IN THE GREATER

Eatonville area for GMRS users, but also being monitored by Radio Club of Tacoma hams who are also GMRS-enabled. The reasoning being to let the GMRS folks learn about ham radio in general via QSOs on the new repeater, and specifically to invite them to the Radio Club of Tacoma and hopefully get their ham license. Please see the pictures for the layout of the repeater.

**It's set up on 462.700 MHz output and 467.700 MHz input, with a 103.5 Hz PL tone.**

I built the system from the top down, both in physical layout and design logic. At the very top of the rack is the transmitter, mounted there to allow heat

to rise and escape naturally. If needed, there's space above it for a cooling fan, and the controller is able to power a low-draw fan or trigger a relay if things get too warm.

**The transmitter is a Motorola Radius M1225** transceiver, capable of both 12.5 kHz (narrowband) and 25 kHz (wideband) operation. I've got it running at the lower power setting—high power just isn't necessary for this application but would be an option. The receiver is an identical M1225.

**Right beneath the transmitter** sits the controller: an [ID-O-Matic](#). It connects to the radio through the



*GMRS repeater as built by Bob W7MXE and donated to the Radio Club of Tacoma.*

*Bob will also oversee the installation in Eatonville, WA*

*Photo by Dave W7UUU*

# Bob K7MXE Club GMRS Repeater Build—but why?!

By Bob K7MXE



16-pin accessory plug. The pinout can be tricky, but I taped a diagram to the bottom of the wood cabinet for reference. The first controller I bought turned out to be a lemon—it was wired wrong, never actually tested, and had faulty parts. I had to return it on my own dime.

The replacement unit from [HamGadgets](#) works properly, but didn't come with the CW ID programmed. It does have the optional voice ID board installed, so that's what it's using for now. Most of the GMRS repeaters I hear in the area ID with CW, so maybe this one will stand out a bit with voice ID instead. Not to mention, most GMRS users are not likely to know Morse code. The ID-O-Matic is programmed via a USB port located right on the edge of the board. You use a terminal program to configure it.

**Combined, the controller and voice module cost about \$125.** I bought the unit through eBay, though similar ones are listed on Ama-

zon as well. The online manual dates back to 2014—not the easiest to follow, but it gets the job done. Power for the controller is supplied by the receiver radio.

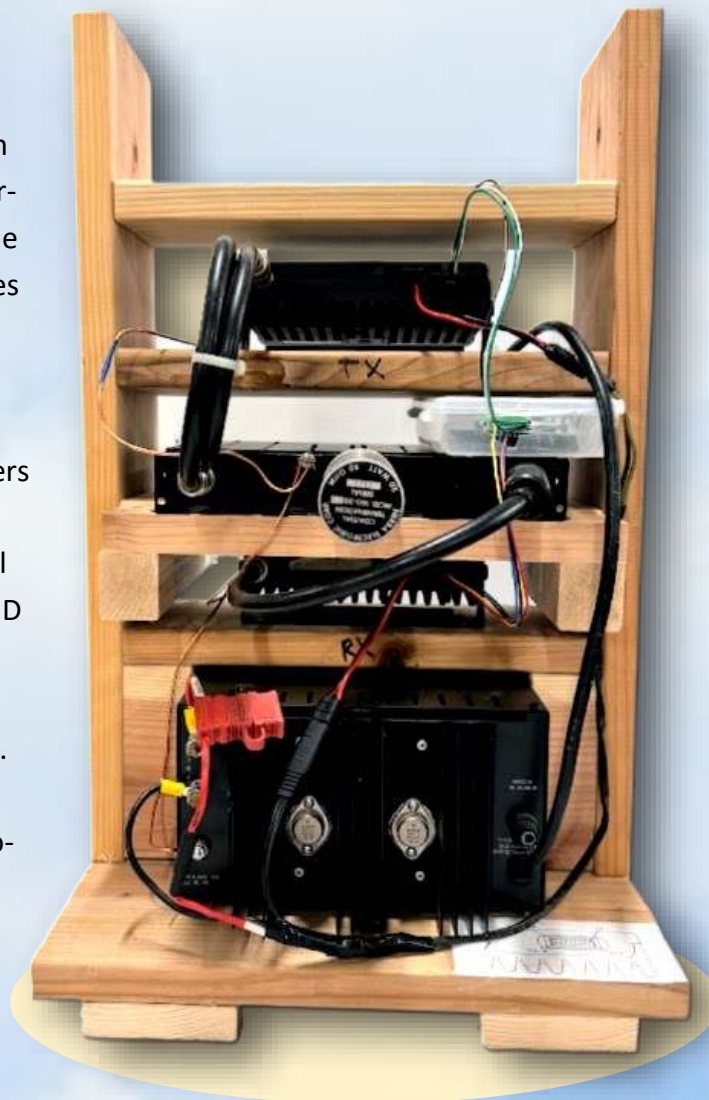

*Rear view of the GMRS repeater as designed and built by Bob K7MXE, then donated to the Radio Club of Tacoma for outreach to the GMRS crowd to introduce ham radio  
Photo by Dave W7UUU*

**Below the controller is the duplexer**—an 8-cavity, 100-watt-rated unit from eBay. I paid \$149 at the time, but now they run closer to \$161 due to tariffs. It covers 400 to 520 MHz and ships pre-tuned to your requested frequency.

All the coax is terminated with type-N connectors, which I had to adapt to fit the Mini-UHF jacks on the Motorola radios. I found some old cables in the junk box with N on one end and PL-259 on the other, then used Motorola adapter plugs to complete the connection.

There are three ports on the [duplexer](#): low frequency (transmit), high frequency (receive), and a center connector that runs to the antenna. I've got it terminated in a

# Bob K7MXE Club GMRS Repeater Build—but why?!

By Bob K7MXE



dummy load for testing.

**The receiver—the second M1225 transceiver**—provides power, audio, and PTT signaling to the controller through the same 16-pin connector. If you link the two radios directly, you can make a repeater without a controller, but you lose all important features like ID, time-out timer, and roger beep.

The power supply is a solid Astron 20-amp linear—

more than needed, but reliable. It came as a donation from the Red Cross via the RCT Property Management team.

**The cabinet is a simple build** made from scrap pine boards I picked up as firewood. I used long drywall screws to fasten it all together. There’s a place out on Mountain Highway that builds sheds and gives away cutoff pieces of 2x4 fir. I swing by about once a

*Click images to view links to the gear*



Scrap “firewood” frame and rack for the gear built by Bob K7MXE



Motorola Radius M1225 transceiver as *Transmitter*



ID-O-MATIC Controller in clear plastic box



SGQ-450K 100 antenna duplexer



Motorola Radius M1225 transceiver as *Receiver*



Astron RS-20A 12v 20A Linear power supply

## THE REPEATER RIG

# Bob K7MXE Club GMRS Repeater Build—but why?!

By Bob K7MXE



week and usually leave with a truckload. That same wood is burning in the stove this morning as I type this.

**The GMRS call sign for this repeater is WSGN231.**

Thanks to Steve Morton **AD7AB** for helping me get it registered—he really knew the ins and outs of the process working with the FCC.

If you're thinking about building a repeater, check out [www.repeater-builder.com](http://www.repeater-builder.com). There's tons of good info there, with ideas and surplus gear from just about every manufacturer.

Before this build, I experimented with a low-power GMRS repeater using Baofeng radios and a 30-watt duplexer. The radios only put out 1.4 watts—not really worth the trouble. In the end, I decided to go with the Radius rigs. These Motorolas don't care if you're running GMRS or ham frequencies.

You can also find low-cost pre-built repeaters on eBay. Some folks piece together setups like mine and sell them as turn-key systems.

So that's about all there is to it. I hope to get it installed in the coming weeks at a location in or near Eatonville and get it on the air for GMRS folks and hopefully welcome them to amateur radio and to the Radio Club itself.

-Bob **K7MXE**



*The Eatonville, WA utility building and tower is one of several locations being considered for installation of the repeater and antenna.*

*Photos by Bob **K7MXE***

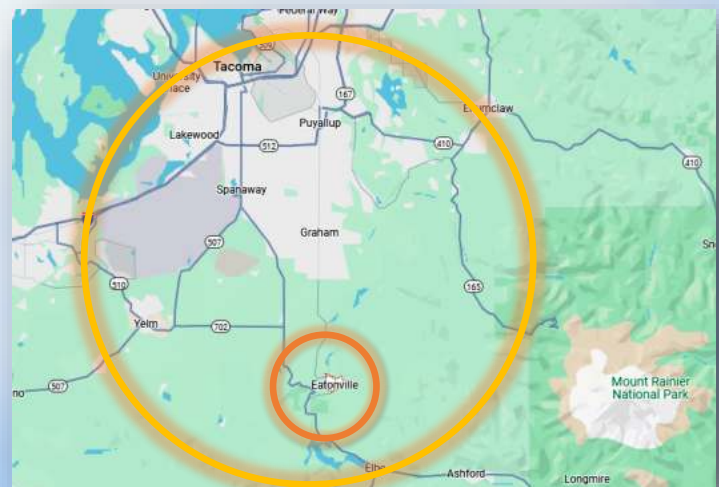

*Large circle: estimated coverage range of the repeater which will be located in Eatonville, WA just to the west of Mt. Rainier*



# THE FRUGAL HAM

## Tubes—on a Budget

**MANY HAMS WANTING TO START WORKING WITH** tubes for the first time end up being shocked at the sometimes-crazy prices these little glass bottles go for on eBay and other online sites. And it's true—finding radio tubes these days isn't quite as easy (or as cheap) as it once was. But if you know where to look and what to look for, there are still good deals to be had. Whether you're building your first tube transmitter, restoring an old receiver, or just trying to build up a stock of useful tubes to slowly learn to experiment with, here are a few of my own tips to help you get started the old-fashioned way—by hunting them down in the wild. Sure, you can turn to eBay or online retailers like [TubesAndMore.com](http://TubesAndMore.com) (which is actually a GREAT source of not just tubes but lots of other parts—but the prices are full-tilt retail.), but it's still possible to beat those prices if you're willing to dig a little. Here's my own list of tips for “frugal tube hunters”:

**1. The OBVIOUS first place to look is hamfests.** There's not a hamfest happening anywhere that won't have tubes—lots and lots of them. But steer away from the ones neatly arranged in their original boxes with a “per tube” price. Instead, look for boxes or bags of loose assorted tubes. Don't be shy about digging through loose tubes. Prices in these bins are often well below the “New Old Stock” (NOS) prices that boxed tubes will usually demand on some of the hamfest tables. It might not be pretty,

but a good eye and a little patience can turn up real bargains. It's not unusual to find a box of “assorted loose tubes” under a table for just a few bucks.

**2. Aside from hamfests, don't rule out flea markets,** junk stores, and possibly antique stores (although most such stores these days treat eBay “sold prices” as their starting point—it's pretty rare to find reasonable prices

on tubes there but it's still something I always keep my eyes out for when shopping).

**3. If it's a “buy the whole box” deal** and you have to take the entire pile, take a moment to scan for tube numbers before you commit. If you see numbers starting with 3, 6, or 12, that's a good place to start. In

most cases, that first digit of the tube type number represents the filament voltage. For most ham radio uses, you'll be dealing with 6-volt or 12-volt tubes. Some 3-volt (and 1-volt) types were used in portable sets and are still worth grabbing if the price is right. And tubes starting with “0” (zero) have no filament—they are voltage regulators and are worth having for many reasons.

**On the other hand, if you see lots and lots of tubes** with numbers like 17, 21, 23, or 38—such as 38HE7, 21LU8, or 23Z9—those are most often TV tubes from the late 1960s and early 1970s. These were usually designed for a specific chassis, with odd filament voltages due to series-





string heater wiring across the AC line. That doesn't mean they're useless—but you won't find many ham radio circuits calling for them.

This tube number is usually lightly stamped somewhere on the glass envelope. It might appear shiny or in faint gray print. If it's hard to read, breathe gently & warmly on the tube like you're fogging a mirror. That will usually make the number "pop" briefly. But *never* rub the number with a cloth, and *never* try to wash the tube—especially the part where the number is printed. That ink is *extremely* fragile, and once it's gone, it's gone for good.



*Tube boxes seen under a ham fest table a few months ago—they were \$5 a box—I passed because I have 1000s of tubes.*

*Photos by Dave W7UUU*

It's almost impossible to identify most tubes once that number is gone.

**4. Once you've found a stash**—large or small—of mostly 6- and 12-volt tubes (and don't pass up "0" volt tubes like OA2, OA3, OD3, etc.), and made your sweet deal with the seller, the next step is figuring out if they're any good. A tube tester would be helpful at this point, and there's an article starting on page 53 of this issue called "[Tube Testers Demystified](#)" to help you get started. But in the meantime, look up the tube number online (or in a reference manual if you've got one—on page 101 of this issue I've listed a great such reference, [Tube Lore II](#)), and find out which pins feed the filament. Then use a multi-meter on a low-ohms scale to check for continuity. If the filament is open, the tube is dead—end of story. Likewise, if you see cracks in the glass, white foggy stuff on the inside, loose metal bits rattling around, or any other sign the tube has lost its vacuum, toss it in the discard pile. No need to waste time testing tubes that are already goners. (Or carefully break them open and see if you can identify all the layers—see the [Ham Tech 101 article on page 117 of this issue](#): basics of tube innards).

**5. After you've weeded those out**, reach out to your local ham club—or possibly a nearby audio hobbyist group (they also love tubes!)—and see if someone has a tester and is willing to help. As a last resort, it's not hard to [build a simple emissions tester](#) to check whether the cathode is emitting electrons and the plate (anode) when positively charged is collecting them and passing current. It won't tell you everything, but it'll give you a sense whether the tube has a fighting chance.

**6. Now that you've gathered up a few keepers**—tubes like 6AU6, 12AX7, 6C4, 6AQ5, 6L6, and so on—make a list of what you have, and start hunting down simple projects that use them. Tubes like the 6C4, 6AQ5, 6CL6, 6AG7,



and 6L6 are all excellent choices for building simple single-tube CW transmitters. See the “Kits and Homebrew Projects” [Page 91](#) (6C4), & [page 93](#) which is an example of a 6AQ5 transmitter kit that comes as a bare PC board. You supply the tube, the socket, and the rest of the parts yourself but the PC board is in essence “fully wired” which simplifies the actual building.

**7. Lastly, here’s some you may consider not dragging home** (just my opinion—it’s up to you!). Start by leaving behind those oddball TV tubes we mentioned earlier— 17, 21, 23, and 38-volt types. Unless you’re restoring vintage TVs, they’re mostly dead weight (although, some day, those will be all that’s left and surely diligent hams will start to adapt to the oddballs as a cheap source to keep on building). CRTs (picture tubes) and camera imaging tubes? Heavy, fragile, and nearly impossible to repurpose—skip them. Compactrons—the multi-section types with 10 or 12 pins from the late '60s and '70s—were made for specific consumer gear and don’t have much use in ham circuits (with certain exceptions—the 6C10 found in the back of every Heathkit SB-610 scope is a triple-triode and even if you don’t want to use it, SELL it! They can go for very high prices to the audio crowd—and often times you can buy a junker SB-610 for under \$20, with that tube included!). Damaged tubes, obviously burned bases, tubes that are white inside, or anything that rattles when shaken can usually be skipped without regret. When in doubt, it’s okay to leave a few behind (unless you have to take the whole box—so take them and trash them later). Better to go home with ten useful tubes than fifty pounds of glass ballast.

**So that’s my own personal list** of “shopping for bargain tubes” at hamfests and junk stores. I’ve found more than you’d imagine in places just like that, including a large TV repairman tube caddy PACKED with 3,6, and 12 volt tubes including many really useful ones (and almost

none of the “TV tubes) for only \$80 which was less than 75 cents a tube.

-Dave W7UUU



*This one I just couldn’t pass up... \$80 for a caddy full of tubes, most “new in the box” and almost zero oddballs!*

*There were well over 120 tubes total (it’s a large case). It was found in a “junk shop” a few years ago in Long Beach, Washington. It just goes to show you, deals are out there—you just have to have a little luck and keep your eyes open!*

*Photos by Dave W7UUU*

# MUSEU TOPICS OF INTEREST:

## Just Some Fun Stuff!



THIS IS A DEFUNCT GENERAL ELECTRONICS, INC. CDR-250TH tube that was converted into an LED lamp. I found it at a hamfest, already converted. The lamp light doesn't photograph well—it's very low level, intended more as a nightlight. It's produced by 3 blue LEDs that have been installed in the base. The original power triode tube however would have been good for a KW (on a good day) in Class-C service but was more typically used in lower power linear applications up to it's rated 250-watt output. In some applications It was even used as an audio modulator tube to drive high-power AM transmitters for commercial broadcasting. It became popular in ham radio on the surplus market in the post-WWII years. But mine? It's just a nightlight in the shack. -Dave W7UUU



SOMETHING WHIMSICAL ARRIVED OUT OF THE BLUE the other day... my good friend & fellow Moderator at [QRZ.com](https://www.qrz.com), Ronnie NZ4X, sent me a "Dave and Anne SusiesPeeps" set made by his wife Susan! What a fun surprise—we love them! Thanks Ronnie & Susan! Click either picture to visit Susan's Etsy shop. And guess what? They even kinda look like tubes!! -Dave W7UUU



# SHERLOCK

SHERLOCK INVESTIGATES: RADIO FAILURES



By Dave W7UU

***SHERLOCK INVESTIGATES:***

**RADIO FAILURES**

**IN THREE ACTS**

***ACT 1***



# SHERLOCK

## RADIO FAILURES ACT 1: THE SCIENCE OF SLEUTHING



### introduction

**LAST MONTH, I PUBLISHED A GREAT PIECE OF WORK** submitted to me anonymously, titled “Sherlock: The 30 Year Transmitter Hunt Mystery”. This story takes readers through a real-life 30-year effort to stop a habitual repeater jammer in an anonymous US city.

I actually *do* know who the writer is, and can confirm that he is in fact a duly-licensed Extra Class ham with 50+ years of amateur radio technical experience. The articles he writes are not AI generated (confirmed by three different “AI detector” websites) but rather are the real deal. He is a prolific writer, but just prefers to remain unnamed for this series, collectively entitled Sherlock (obviously an homage to Sir Arthur Conan Doyle’s famous private investigator, Sherlock Holmes).

This month we again present Sherlock, with the first act of a fascinating 3-part glimpse into sleuthing out difficult ham radio repair problems, all drawn from his own years of bench repairs.

**Here is an outline of the series:**

**Act 1 August: The Science of Sleuthing:**

- ◇ Introduction and mindset
- ◇ Overview of failures
- ◇ “Black Widow” transistor
- ◇ “Denny Dendrite”
- ◇ The “Green Radio”

**Act 2 September: Salt, Whiskers, and Scintillation:**

- ◇ 3.5% saline failure
- ◇ Tin whiskers
- ◇ Tantalum capacitor scintillation
- ◇ Electrostatic discharge
- ◇ “Open Case” transistor issue

**Act 3 October: Cracks, Common Failures, and Final Clues:**

- ◇ Solder joint failures
- ◇ TS-440 foam reversion
- ◇ Audio cap polarity design flaws
- ◇ List of basic investigation equipment
- ◇ Safety precautions for circuit sleuths
- ◇ Resource epilogue

As with the July opening Sherlock article, you’ll find his writing clear and concise, evoking a true sense of the famous British detective himself—only here, he’s solving “mysteries of electronics failures” instead of hunting criminals.

Surprisingly, the two have quite a lot in common.

I hope you enjoy reading along. I sure did.

-Dave **W7UUU**



# SHERLOCK

## RADIO FAILURES ACT 1: THE SCIENCE OF SLEUTHING



### Act 1: The Science of Sleuthing

#### Sherlock Investigates Radio Failures

If you don't ask yourself, "Why do things fail?" you are missing perhaps the most exciting part of your electronic hobby. When you have a piece of equipment that fails, do you just throw it away?

Analysis of the failed item can be the most interesting part of your electronic experience. It can lead to new designs or modifications to improve your equipment.

Most of our current electronic equipment is designed to be replaced at the subassembly or printed wiring board assembly level, but that doesn't prevent you from trying to find the root cause of a failure at the piece-part level.

Sometimes your investigation will lead to a simpler repair action that will save the subassembly or unit. Design and construction of electronic components can be studied on Wikipedia [[LINK](#)]. It has a large database on how these components work.

#### Sherlock's Science of Deduction applies to us all:

It is keen to apply the precepts of advanced *detective procedures* in these matters:

"It is a capital mistake to theorize *before one has data*. In-sensibly one begins to twist facts to suit theories, instead of theories to suit facts." (*A Scandal in Bohemia*)

"When you have eliminated the impossible, whatever remains, however improbable, must be the truth." — S.H.  
(*The Sign of Four*, Ch. 6)



"The world is full of obvious things which nobody by any chance ever observes." — S.H.

#### Statement of the Cases:

I have left out all the flummery and verbose descriptions that Dr. Watson would have added if he were recording these stories, so you will have to imagine your own settings. However, some of these stories did begin, "On a dark and stormy night."

"Many of these singular happenings have never before until now been fully dealt with in any public print." — S.H.



#### The Episode of the 'Black Widow' Transistor:

One of the most devious failures ever encountered involved the 'Black Widow' transistor in a push-pull switching power supply. Female black widows have been known to eat their mates. The male spiders still haven't figured this out.

# SHERLOCK

## RADIO FAILURES ACT 1: THE SCIENCE OF SLEUTHING



This failure occurred in a TO-39 power transistor (2N3553) that had a big copper slug inside the case, crimped in place. The case had three dimples on the side that grabbed the internal copper header.

In this singular case, one transistor in the circuit burned up and shorted. It looked like secondary avalanche breakdown — a collector-to-emitter short. There was significant melting of the die. The transistor was replaced, but after a few temperature cycles, the newly installed transistor failed again in the same spot. Aha! The spider got another one.

The root cause was traced to the 'good' transistor in the push-pull pair. It was opening up and latching the other one 'on'. The crimp on the header can was the only electrical connection to the collector, and when it opened up, the other transistor was turned 'on' with full DC current, which melted it. So remember: in any push-pull circuit failure, the 'good' part might really be the 'bad' part — however improbable it may seem.



### The Midnight Flight of Denny Dendrite:

It was a dark and stormy night, really, when the intrepid Denny Dendrite electronic sleuth made his way, carrying a dendrite to a secret laboratory in Washington, D.C., for analysis. Arriving at 3 a.m. after a transconti-

mental flight in winter, a dozen government investigators stood ready at their SEM and Auger equipment.

The defect had just been confirmed on an integrated circuit that used leaded (Pb) glass sealing material. The surface of the sealing glass provided a platform for pure lead [dendrites](#) to grow from one IC lead to another under high-impedance electrification.

These are easily visible using a microscope. Indeed, many YouTube videos show the growth process.

Click the image below to watch a *great short* YouTube example of this effect in action:

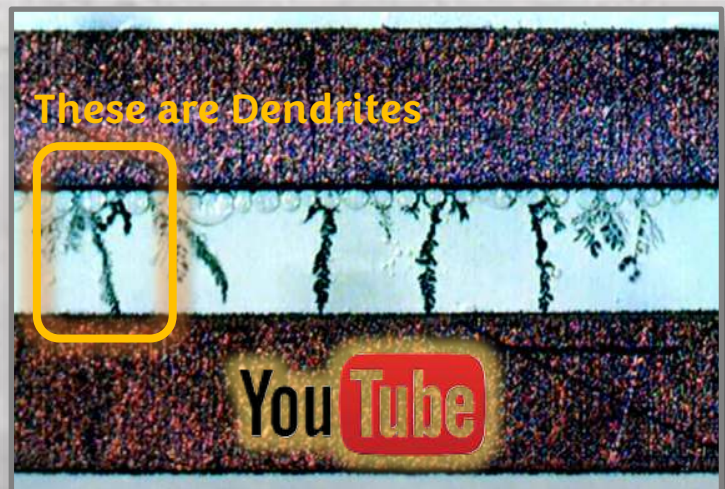

These failures are often induced when a unit is taken from a *dry, cold environment into a warm, humid one, causing the unit to pass through the dew point*. Water condenses out of the air and can cause dendrites. There is usually enough carbon dioxide (CO<sub>2</sub>) in the air, or acidic residue on a circuit board, to start dendrite growth. **Do not apply power** to a unit that has gone through or is going through the dew point until it is completely dry. Remove any memory backup battery — *it will cause new den-*

# SHERLOCK

## RADIO FAILURES ACT 1: THE SCIENCE OF SLEUTHING



*drites to form.*

The use of 'freeze mist' for troubleshooting is highly discouraged because it causes frost to build up on the components, which all get wet as they come back through the dew point. Obviously, it can cause dendrites that will mask the clue being investigated. Elementary, isn't it? If you must lower the temperature of a part, use an ice cube in a plastic bag.



### The Intermittent Green Radio:

This radio performed perfectly for many years but was infrequently used. After field testing in hot weather, the unit would fail after a few hours of operation. The radio has many internal protection circuits, so it just shut down, and no internal damage was found. The radio would work fine the next day.

Troubleshooting began at the power supply circuit, and using a heat gun, the unit could be made to fail quickly when it was hot. Switching to a soldering iron to gently heat the components, the failure was isolated to a tantalum capacitor. The capacitor was physically reversed in its circuit. After replacement, there was no more intermittent high-temperature failure. The part had simply been installed with re-

versed polarity. Tantalum capacitors can operate *for many hours* in the reversed direction but will eventually short out.

The printed circuit board did not have any polarity markings, and it escaped visual inspections. This expensive radio was repaired for the cost of a two-dollar part.

Another similar failure occurred in a similar radio caused by an overheating TO-220 transistor. The transistor was mounted with a small insulated plastic bushing to keep the mounting screw from shorting to the chassis. During assembly, the bushing/washer became smashed under the transistor body and prevented it from fully seating on its heat sink. The transistor could not dissipate heat and caused the radio power supply to shut down. Re-seating the transistor flush onto the heat sink fixed the unit.

*-Sherlock*



**Join us in September** for the next act in this series:

*Salt, Whiskers, and Scintillation.* Thanks to our anonymous benefactor for his wonderful work.

*-Dave W7UUU*



# Tube Testers

*Demystified*

# Tube Testers

## *Demystified*

By Dave W7UUU

WHEN WE TALK ABOUT TESTING VACUUM TUBES, most folks “of a certain age” immediately think of those old gray or gold cabinets in the corner of the drugstore or Radio Shack with the giant tube charts. There were seemingly a bazillion mysterious flip switches and dials, and the can’t-miss-it great big meter labeled “REPLACE”, “?”, and “GOOD.” But behind that friendly front end, there’s actually a wide array of tube testing methodologies that evolved over the decades from simple to scientific.

While the average ham with tube gear or tube-type home TV or table radio might just want to know if a tube is “good or bad,” engineers and designers have long been concerned with something more nuanced than just good or bad: how a tube *performs electrically*, whether it's suitable for audio amplification, RF transmission, or just glowing pretty in the pilot light socket of a 1940s console in a role that doesn't demand much performance. They want *metrics*. They want to “match pairs” so devices with multiple same-type tubes have the same characteristics and work well together in pairs, trios, or quads.

**At the heart of tube testing lie several fundamental techniques**, each with its own strengths and limitations. The most common types of testers include emission testers, mutual conductance (or transconductance) testers, so-called dynamic testers, and a few lesser-known specialty testers. Understanding the key differences comes down to what exactly is being tested — cathode emission current, plate current variation in response to control grid voltage, or a dynamic signal response.

### So what do these terms all mean?

Let's start with the simplest and most widely produced design: the basic emission tester. These were the bread and butter of drugstore tube checkers, especially models made by companies like Mercury (who made most of the Radio Shack testers), Seco, and Eico (both brands common in drugstores). Most simple testers purchased by John Q. Public were of this variety... inexpensive and easy to use.

An emission tester works by connecting the tube's cathode (the part of the tube that emits the electrons, closest to the filament and usually surrounding it) to a positive voltage through a meter, then completing the circuit through the plate (also called the anode). The idea is to measure the *total*



Beautiful 1955 Jackson 103 Dynamic Tube Tester spotted at Josephine's Mercantile in downtown Port Orchard—photo by Dave W7UUU

# Tube Testers

## *Demystified*

By Dave W7UUU

*electron emission* capability of the cathode, essentially using the tube as a diode, usually with all grids tied to the plate or otherwise biased to allow conduction through the vacuum of the tube with no interaction from the grids at all.

If the cathode can still emit sufficient current, the tester's meter needle swings up into the green.

**It's a quick and dirty test, but *not without value*.** If a cathode (including the filament itself) is badly depleted, or the tube is gassy, or the cathode or plate (anode) connections are open, the emission tester will usually spot it. At that point, any more advanced testing is pointless—the tube is just plain bad. Who cares if the grid(s) work fine if the emission from the filament/cathode is lacking?

**The problem with emission testers** is that they don't replicate *real-world operating conditions*. In a proper circuit, a tube is typically used with bias voltages applied to the grid, and the plate current changes *dynamically* based on those voltages. Emission testers ignore all of that entirely. They don't measure mutual conductance (between elements inside the tube), which is a key performance spec for most any tube beyond a rectifier. As a result, a tube can pass with *flying colors* on an emission tester and still sound muddy or distorted in a hi-fi amp, or fail to oscillate in a VFO. And that's where the transconductance, or mutual conductance, tester steps in.

Mutual conductance is a parameter defined as the change in plate current *divided by* the change in control grid voltage, typically measured in micromhos ( $\mu\text{mhos}$ ). It's a direct measurement of the

tube's amplification factor in real circuit conditions.

Testers like the Hickok 539B, TV-7/U, or B&K 707 apply fixed voltages to the tube's elements and then superimpose a small AC signal on the control grid. The tester then measures the corresponding AC component of plate current and, using a reference circuit, translates that into a micromho reading ("matched" tubes seek to have this number be the same for each tube in the "matched" set).

**It's a far more meaningful number than just raw cathode current representing emissions.**

The Hickok testers, in particular, used a clever bridge circuit developed by Alan Douglas and his colleagues at Hickok's labs. They employed a "mutual conductance bridge" that balanced out at a certain plate current change. The resulting meter reading was proportional to  $G_m$  (transconductance). The Hickok testers also used a pulsed DC plate voltage instead of continuous power to reduce heating and stress on the tube under test. That is why many Hickok testers have an unmistakable "thump-thump" sound from the transformer when running — the plate voltage is being switched at  $\sim 60$  Hz or so, timed to the AC power line frequency.

**Transconductance testers are often seen as the "gold standard," and for good reason.** They catch weak tubes that would otherwise pass on a simple emission test. But they're not foolproof either. Some of them use average values rather than real dynamic response, and depending on the signal frequency used, they may not catch subtle issues in RF tubes or tubes with *frequency-dependent* characteristics

# Tube Testers

## Demystified

By Dave W7UUU

(being linear devices, tubes can behave very very differently depending on the frequencies they are presented with).

They also require more precise circuitry and calibration, which is why many hamfest-bargain testers in this more rarified air need a full overhaul and usually a full re-calibration before giving reliable results.

**Then there's the so-called *dynamic signal testers***, which tried to take it a step further. These units, such as the Triplet 3444 or the later B&K 747 (my tester of choice these days), applied a small AC signal and monitored actual output amplification or distortion. They didn't just measure transconductance statically — *they evaluated the tube's behavior under realistic audio or RF-like conditions*. While these testers are closer to how a tube behaves in-circuit, they were also more complex, more expensive, and not as widespread. They require calibration (alas, mine was last calibrated by a professional way back in 2007). Their test sockets often had “actual factual real world” high voltage on them during operation, which made them trickier (and a little riskier) to use.

***One lesser-known category worth mentioning is the curve tracer***, used almost exclusively by labs and tube gear design engineers. These don't just give you a number — they give you a *graph* of the tube's performance. By sweeping the grid voltage and plotting the plate current, a curve tracer can generate “characteristic curves”, much like those seen in the old RCA tube manuals. High-end test gear firms Hewlett-Packard and Tektronix both made curve

tracers with special fixtures for tube testing. These are the *ultimate* in diagnostics but are obviously overkill for the average ham trying to figure out why his VFO drifted off frequency at 3 a.m. or if his 6146B in the “Novice Rig” has died.

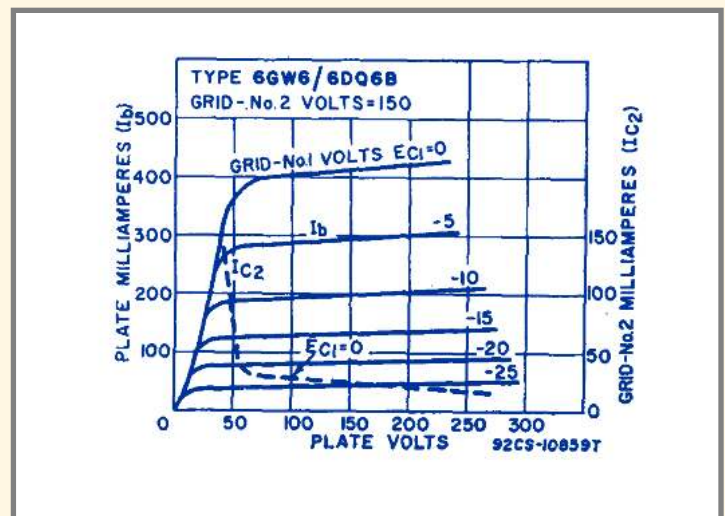

Typical RCA Tube Manual “curve tracer” graph

**Each method has its place.** Emission testers are simple, fast, and give a quick go/no-go result. *They're perfect for culling out obviously bad tubes from a pile of ham fest finds.* Transconductance testers give a better picture of performance, especially for audio and RF tubes where gain and linearity matter. Dynamic testers get you even closer to how the tube behaves in service, and curve tracers are for those who want to dive all the way down to the characteristic curves—not likely needed by most hams.

The choice of which type to use often comes down to what kind of work you're doing. A guitar amp tech may swear by the rugged old B&K 707 for checking 6L6s and 12AX7s quickly and accurately. A

# Tube Testers

## *Demystified*

By Dave W7UUU

Collins collector might prefer the precision of a TV-7 or 539C, both military-tested and built like tanks. Meanwhile, an experimenter building homebrew tube-type ham gear from scratch might benefit from access to a curve tracer just to match output tubes for best performance in a transmitter.

### **Of course, none of these testers can catch everything.**

Shorts, leakage, noise, gas, and microphonics often require separate tests or subjective evaluation. Many testers include buttons or toggles for shorts, grid leakage and cathode-to-heater leakage, often using neon bulbs or sensitive voltmeters. Others might rely on your ears — literally — to hear a microphonic rattle.

**But let's not forget: the best tube tester is often the circuit the tube is designed for.** If it works properly and sounds and performs well in your Collins or Hallicrafters receiver, it works. Never mind what the tube tester says—it's being "tested" in the very circuit for which it was designed.

Still, there's a kind of nostalgic joy for many of us in plugging a tube into a tester, carefully setting a whole bunch of selector switches like a mad scientist in his lab, hitting a "Test" switch, and then watching the needle creep toward **Good**... or not—the horror of seeing the needle barely move to the right, stopping in the red **"Replace"** section or—*God forbid*—the horrible "?" spot on the meter! That's just the worst. We all want either "fast shoot to green" or "slow slog to replace" ... but that damned question mark in the middle... *pure angst!!* (readers will either know this and share that feeling or you won't have a clue what I'm talking about!).

### **Tube testers are a delightful blend of science and nostalgia**

— a way to connect with the golden age of electronics while attempting to keep your radios running strong into the future. And whether you're testing with a humble

emission checker for "go or no-go", or a high-end lab-grade curve tracer, you're carrying forward a tradition of practical electronics that's as relevant today as it was in the age when glowing bottles called tubes were being made.

**And to close this article out**, know that when I was a wee lad of 20 in 1981, I worked for Northwest Radio & TV in Tacoma, WA and had the real-world experience of being a TV repairman, complete with a caddy full of 75 typical television tube replacements at the ready to fix a TV set in the owners home. I wouldn't trade that experience for anything. Even though it was near the very end of the "retail tube era" it remains an important part of my experience and memories.

-Dave W7UUU



Typical TV repairman tube caddy like I used in 1981

Photo by Dave W7UUU

# Tube Tester

## Examples

By Dave W7UUU

**TUBE TESTERS HAVE BEEN AROUND ALMOST AS** long as vacuum tubes themselves. While John Ambrose Fleming introduced his basic diode tube in 1904, and Lee de Forest followed with his revolutionary Audion triode in 1906, it wasn't until around 1920 that vacuum tubes entered mass production—

the market shortly thereafter. At the height of their popularity, as many as 30 different companies were building tube testers, resulting in more than 500 distinct models over the decades.

By the early 1980s, the era of the tube tester was nearly over, with only a few manufacturers still sell-

ing them. Funke in Germany, and Hickok (possibly B&K as well) in the U.S. held on into the early 80s. But during their heyday, names like Hickok, Triplett, Supreme Instruments, B&K, Sencore, Precision Apparatus Company (PACO), Eico, Knight, Heathkit, Jackson, Mercury (often seen in Radio Shack stores), and SECO (a fixture in many drugstores) were familiar to nearly every ham and electronics tech who worked with tubes.

The earliest commercial tube tester example I could find for this article is the “Confidence Automatic ADCO Radio

Tube Tester” which was a mass-produced

tester that came out about 1930. Apparatus Design Company (ADCO) was based in Little Rock, Arkansas. Their tester was very likely the first really popular such device to come out.

With 3 tube sockets, a rotary selector dial with 20 testing positions, and a jumper patch panel, users could test just about every tube type that was available in the early 1930s.



*ADCO Tube Tester, ca. 1930*

Photo: [Etsy seller mydustdrawer](#)

thanks largely to RCA becoming the first major player in large-scale tube manufacturing.

Not surprisingly, the need to test those early tubes quickly followed. Tube testers began appearing on

# Tube Tester

## Examples

By Dave W7UUU

The remainder of this article will cover examples of tube testers from my own collection, from the collections of local ham friends, as well as from the W7OS Doc Spike Museum at the W7DK Clubhouse.



Photo: Dave W7UUU

This Heathkit TC-2 tester (as featured on the cover of this month's *Bark*) is from my own collection. It's just a very basic emissions tester, so just a "go or no-go" without any of the more advanced testing functions. There is a shorts test button and a filament continuity test. But it's very useful to simply weed out totally shot tubes quickly. I keep it in my arsenal of test gear simply because it can at least do emissions testing on the really old 4, 5, and 6-pin tubes which most of the more modern testers (like the B&K 747) can't do. Of course, such testers can be made to test the older tubes but it requires building a base adapter, and coming up with settings of other tubes that closely match the older tube. The paper settings roller chart (lit up in the photo) I never use. Most of these old testers with roller charts simply don't roll well anymore or the paper is ripped. But virtually all of them have all the possible tube settings listed in PDF format to download and print as a book format (stored in the lid of the tester usually). The Heathkit TC-2 dates to about 1955.



From the collection of W7DK, photo by Dave W7UUU

Two very basic emissions-type tube testers. Mercury (above) was one of the major brands of testers in the 1960s and 70s. In fact, most of the floor testers in Radio Shack stores were made by Mercury (some also by SECO and Sylvania, depending on the era who got the contract). These are just simple go, no-go testers. Below is another big brand at the time, EMC. The model 205 dates to about 1945.



Photo: [Joe Haupt](#), Wiki Commons

# Tube Tester

## Examples

By Dave W7UUU



TV-7/U from the W7DK collection, photo by Dave W7UUU



B&K 747 from the collection of Dave W7UUU

The **TV-7 series of tube testers** are today the most sought after by radio restorers as well as tube audio aficionados. It's an extremely comprehensive high-performing tester. Being a transconductance tester (also known as mutual conductance), the TV-7 delivers very accurate results, stopping just short of the more advanced curve-tracer type of tube tester.

There were a number of variants manufactured to military specifications under contract by the U.S. government throughout the 1950s. The TV-7/U as above, from the W7OS Museum shop of the W7DK radio club, was made by either Superior Instruments or Western Electric (I didn't see exactly which on the ID plate when I took the photo). Other variants such as the TV-7A/U, TV-7B/U and TV-7D/U were made by Hickok and Weston, with smaller contracts issued to Triplett as well. But they are all based on the Hickok core circuit, the dynamic mutual conductance bridge designed by Alan Douglas at Hickok.

Full calibration information is easy to find to keep your TV-7 in tip top shape. But if you don't already own one, you're in for a surprise when you start shopping... prices today for any variant of the TV-7 easily run \$800 and more depending on condition.

**Sort of bridging the gap** from a basic emissions tester like the Heathkit TC-2 featured on the cover of this month's Bark and the top-end TV-7 series is the B&K 747 dynamic mutual conductance tester. It's much the same as the TV-7 in how it works but with a much simpler circuit. It measures transconductance like the TV-7 but uses a simpler solid-state circuit to simulate the Douglas/Hickok mutual conductance bridge. The meter reads directly in micromho ( $\mu\text{mho}$ —an expression of conductivity, also sometimes referred to as a siemens). When you hear of "matched tubes" that's what they are talking about—tubes having nearly identical conductivity across all the elements of the tube.

The 747 came out in the early 1970s, from B&K Precision Corporation based in Chicago. While this model doesn't quite offer the lab-grade precision of the TV-7 or a Hickok 539C, it's about as close as you can get for all-around ham radio shop and hi-fi use. Prices these days tend more between \$400 and \$600, and it's still easy to find calibration information. I had my own 747 (seen above) calibrated professionally in 2007 but it still seems pretty spot-on even today.

# Tube Tester

## Examples

By Dave W7UUU



Hickok 605 from the W7DK collection, photo by Dave W7UUU

Hickok 600 from the collection of Jim W7VK, photo by Dave W7UUU

**The two tube testers on this page look very similar**, and in fact are variations of the same theme. Left is the Hickok 605 that lives in the W7OS Doc Spike museum at the W7DK Radio Club. Like the TV-7 and B&K 747, they are both also mutual conductance testers capable of directly displaying transconductance measurements, just like the B&K 747 but without the extra complexity of the TV-7 series. Both have the same sort of internal paper roll tube settings chart like the Heathkit TC-2 and many other testers. (As with the TC-2 etc. the tube charts are very easy to obtain in PDF format these days to be printed, and save wear and tear on the internal paper roll). On the right is the Hickok model 600 owned by Jim W7VK. The key difference between the two is that the 605 also includes a multimeter function. This allows it to measure 0 to 1000 volts in 4 ranges, resistance up to 100 megohms, inductance up to 70 Henries, capacitance up to 50  $\mu$ F, current in three ranges (10, 100, and 500 mA), and decibels from -10 to +50. All of these metering functions fit well with servicing ham gear, tube televisions, tube test gear, and of course ham radio gear. On the used market, both models price out in the same range as the B&K 747—\$300 to \$600 depending on condition, etc. ■

# Tube Tester

## Examples

By Dave W7UUU



*M1KTA homebrew valve tester, photo by M1KTA*

**Some folks even build their own tube testers!** Simple ones aren't all that hard to build, and can be set up to test all sorts of tubes. In the case of the **M1KTA** tester above ([LINK to his blog](#)), he's built a very simple emission tester with an added function called "Grid Shift". While not a standard term in tube testers, in the case of this tester "grid shift" refers to varying the control grid (g1) voltage (the "grid bias") and observing how the tube's plate (anode) current responds. It's a static test of the tube to see if it can be biased properly and can even be used to "match tubes". To read more be sure to visit his blog. ■



*Jackson 103 found in a [local store](#), photo by Dave W7UUU*

**While browsing in Josephine's Mercantile** in Port Orchard, Washington, this beautiful tube tester caught my eye on the same day I started this article. It's a Jackson Model 103 mutual conductance (transconductance) type tube tester. Again, that means it is not just an emissions tester but also measures the transconductance of the tube elements inside to give a more accurate indication of tube quality. Jackson started out in Chicago in the 1950s but later moved to Dayton, Ohio. This tester probably dates to the late 1950s. Some Jackson tube testers list Chicago in the panel lettering, others say Dayton which is the case here. The Model 103 is simple but pretty ruggedly built, and still used by hams and Hi-Fi hobbyists due to its more advanced testing capability. This model doesn't fetch high prices like some of the others—typically under \$100. In fact, as of this writing, this tester is still in the shop for sale for \$95 (obviously the booth seller checked eBay before pricing it!). ■

# Tube Tester

## Examples

By Dave W7UUU

### Self-Service Tube Testers

For the final tester in this series, I really wanted to include a “floor tester” for the younger readers—many of whom have likely never even heard of such a thing. Once upon a time, in the 1960s and into the '70s, virtually every drugstore in the U.S.—and every Radio Shack—had a self-service tube tester.

These testers first started appearing as early as the late 1920s, but it wasn't until the '60s and '70s that merchants really caught on to how high the profit margins on tubes could be.

The testers were always stocked with the most common tube types used in home radio and TV repair—though not so much for ham radio, I'm sorry to say. Rare or oddball types could be prepaid and ordered in. Ham power tubes like the 6146 family fell into that category, as did “magic eye” tuning tubes like the 6E5 and many other less common types.

Customers would bring in a box of tubes, look up the settings, and test them one by one—hoping to fix their table radio or TV without shelling out for a professional. Many figured that shotgun-replacing all the tubes would do the trick, and that was often exactly what they did—even if it never fixed anything.

When I worked at Radio Shack (#3322, 6th Avenue in Tacoma, WA), we all figured the tester was biased to show “replace” even when the tube was probably still good enough to use. Customers said the same thing. But we never really knew for sure. What we *did* know was that most folks left the store with new tubes in hand—or a prepaid order for something less common. (And we all got our 3% commission on those sales).

One of my regular jobs in 1979 was to keep an eye out for someone finishing up at the tester, then go over and reset all the controls to their starting positions for the next person.

Virtually all of the Radio Shack testers were made by Mercury Electronics Corporation of Mineola, New York. Depending on the year, some were also supplied by Sylvania. Most of the generic drugstore models were made by SECO Manufacturing Company of Minneapolis. (The example shown at right is a SECO tester.) Fun nostalgic stuff here!

—Dave W7UUU



SECO drugstore tester—Photo: Terry S. [\[LINK\]](#)



*President Adam W2NCC hangs out with Leonard KA7NWF waiting for the Eagles Aerie to open*



*Once inside, Prez Adam and Secretary Gary WG7X gear up for the meeting....*



*... while the members hang out for "social hour" before the meeting starts, and enjoy their Eagles Club hotdog*



*The club always likes to have a good hour of chit chat before getting down to business*

*All photos this page provided by  
Dave W7UUU*



As the meeting starts, more Zoom participants chime in as President Adam **W2NCC** and Secretary Gary **WG7X** get rolling

The crazy-hot weather this day kept a lot of attendees at home and logging in via Zoom—it was a light crowd



Absolutely fabulous presentation by John Beaston **K7TY** of Manzanita, Oregon—covering his community’s amazing efforts of combining the Amateur and the GMRS operators in his area for emergency as well as daily and weekly nets

Paul **W7PFU**, David **AC7KP** and Jeff **W8NGS** in rapt attention as John wowed the crowd with his presentation

All photos this page provided by  
Dave **W7UUU**



Mike **W7MKE** has questions for our presenter...



...as does Dennis **KJ7DDW**



While watching the program, Phil **K7PIA** fires up his assortment of great "Show and Tell" rigs for later



Our club's de facto Safety Officer Doug **AB7DG** also has a number of questions for our presenter

All photos this page provided by  
Dave **W7UUU**



Eagles Aerie #2933 South Tacoma



During "Show and Tell" Phil **K7PIA** brought a number of cool new rigs to present to the club



Phil was especially thrilled with his new zBitx transceiver and all its many built-in features—fun little rig!



We closed out with our monthly door prize, with Julie **W7JUL** winning a much-wanted Antenna Book, while hubby Brad **KK7YQC** smiles to hide his envy!!



On the second drawing, Stephen **AD7AB** picked his prize as this awesome Radio Club of Tacoma shirt!

All photos this page provided by  
Dave **W7UUU**

# STRAY TOPICS OF INTEREST:

## The Tube That Never Was

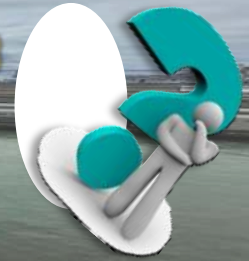

### THE TUBE THAT NEVER WAS

Filed in 1924 and granted on April 16, 1929 as [U.S. Patent 1,700,659](#), Frank Conrad’s “Multiple Electrode Vacuum Tube” was an ambitious idea aimed at packing more function into a single tube glass envelope. The design proposed an unusually complex internal structure: a single vacuum tube containing multiple independently operable units, each with its own grid and plate, but all sharing a common cathode. One variation allowed for three independent amplifying paths within one envelope, while others proposed more elaborate electrode geometries that blurred the lines between detector, amplifier, and mixer.

The intent, as [laid out in the patent](#), was to reduce the number of tubes required in a receiver or transmitter circuit—cutting down on space, power consumption, and cost. By consolidating multiple stages of amplification or detection into a single envelope, Conrad was attempting to create a new type of tube that could allow for radio gear to become smaller, more efficient, and easier to maintain.

#### But despite the promise, there is no evidence

I could find anywhere that suggests this tube ever made it to production. No assigned tube type numbers, no ads, no surviving examples. Unlike other multi-unit tubes of the era—like the later 6SN7 or 6J6—Conrad’s design seems to have lived only on paper. If there were ever functional prototypes, there’s no record of them anywhere.

**Was it ahead of its time?** Or too complex for 1920s manufacturing realities? Either way, Conrad’s invention quietly vanished into the archives. It remains a curiosity—an early attempt to do more with less, and an example of innovation that never left the drawing board. |

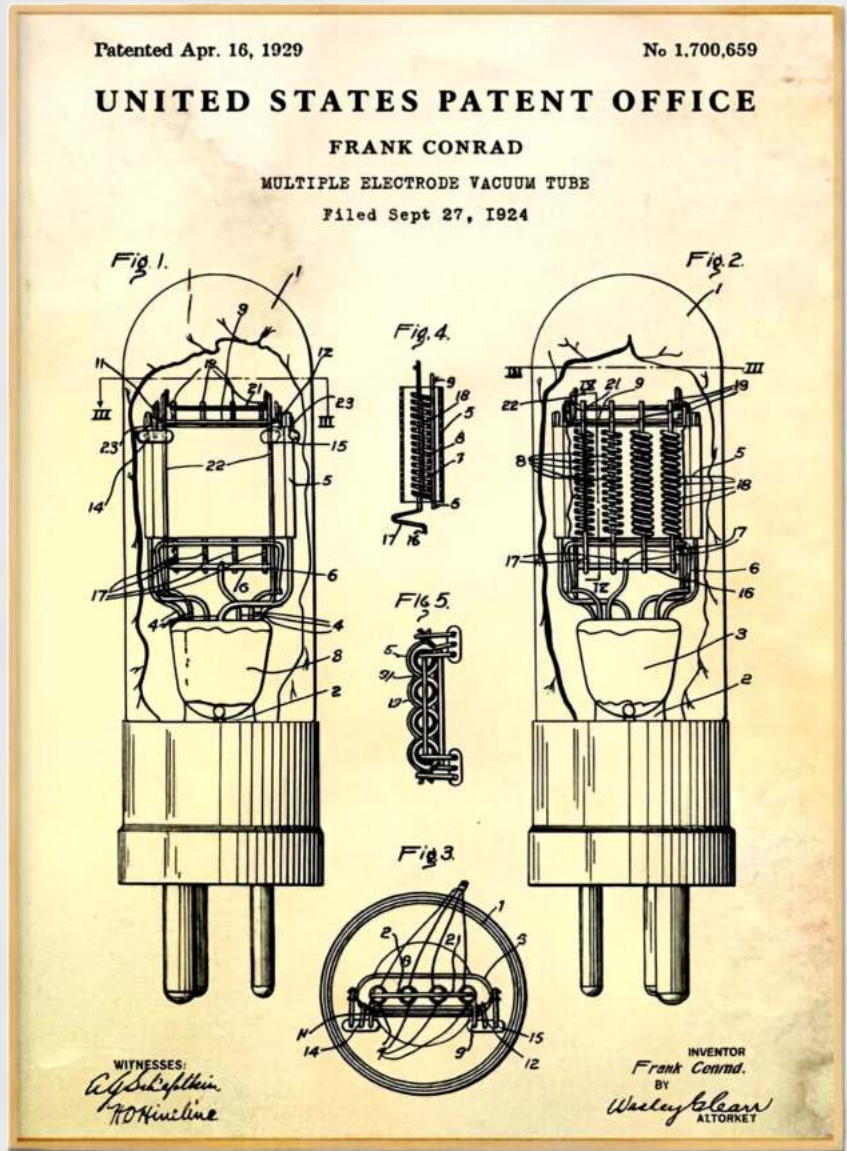

found that you can even buy Conrad’s patent made into a wide array of home and lifestyle décor! Click [HERE](#) to see what I’m talking about. While Conrad probably never made a dime on his invention, the beautiful patent artwork is sold all over the internet as art—by sellers who likely have no idea what it even is... “The Tube that Never Was”

-Dave W7UUU

# ADAM'S TECH TALK

Adam Barbera W2NCC

## TUBES AND THE VACUUM OF OUTER SPACE

When we think about vacuum tubes, we usually picture the reddish-orange glow inside the glass capsules of grandpa's old radio. But one of the most complex and advanced tubes ever built is still flying today aboard modern spacecraft. That's right — the Europa Clipper, launched in October 2024, uses [Ka-band Traveling-Wave Tubes \(TWTs\)](#) to transmit data back to Earth.

**So let's take a closer look.** A TWT is a special kind of vacuum tube used to amplify microwave frequen-

the speed of the electron beam. As the RF signal interacts with the beam, electrons transfer their energy to the wave, amplifying it. Put simply, the TWT converts the electrical power in the electron beam into *amplified RF power*.

### So why is the TWT such a complex tube to build?

For starters, it demands extremely precise alignment of the electron beam and the helix or cavity structure. The internal electron optics — the arrangement of electrodes and focusing magnets — must be carefully tuned to keep the beam on track. Magnetic focusing keeps the beam stable and confined to the axis of the helix. If the beam strays and

strikes the helix, it can create unwanted heat and potentially damage the tube.

The design also requires a very high vacuum to keep gas molecules out of the way. Even a trace of gas could scatter the beam, degrading performance. During

manufacturing, powerful vacuum pumps remove all air and contaminants to ensure a clean environment. Finally, the tube includes multi-stage depressed collectors that efficiently recover unused electron energy — improving overall power efficiency.

**TWTs aren't just a thing of the past.** Spacecraft like Voyager 1 — launched in 1977 and currently the farthest human-made object from Earth — and Voyag-

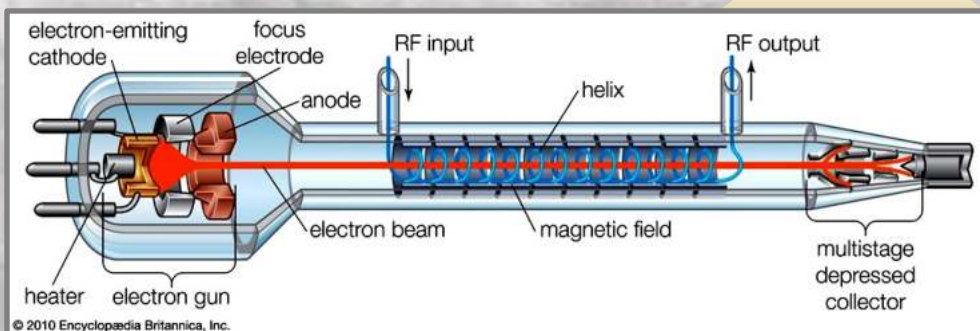

*Pictorial of the workings of a TWT  
Photo: Encyclopedia Britannica, Inc.*

cies. Unlike a basic triode or pentode, the TWT combines a variety of physical principles that make its design both complex and unique. It starts with an electron gun that fires a focused beam of electrons. Surrounding that beam is a helix wire — which looks like a stretched-out spring — or sometimes a coupled cavity structure. Each approach has its own advantages. What they have in common is that they slow down the RF wave enough to match

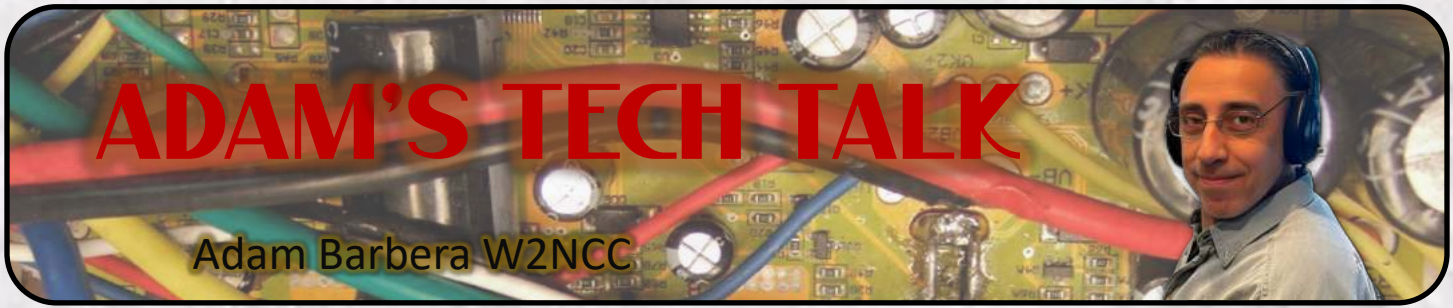

# ADAM'S TECH TALK

Adam Barbera W2NCC

er 2, also from 1977, use TWTs in their communications systems. So does New Horizons, launched in 2006, which flew past Pluto in 2015 and is now exploring the [Kuiper Belt](#). Even commercial satellite constellations like Inmarsat's Global Xpress network rely on TWT amplifiers (TWTAs) for broadband service.

**First developed in the early 1940s**, TWTs have proven remarkably durable. More than 80 years later, even with all the advances in solid-state devices, they remain a mainstay in spacecraft communications. The TWT is a great example of how vacuum tube engineering — combining microwave physics, electron optics, and ultra-high vacuum techniques — continues to power some of our most critical technologies, even in the depths of space.

-Adam W2NCC, President

## Fun Fact: Tubes vs. Transistors in Space

Most folks might think vacuum tubes are relics of the past, long since replaced by transistors and integrated circuits. But in the harsh environment of outer space, tubes still have an edge in one important area: radiation resistance.

High-energy cosmic rays and solar radiation can wreak havoc on solid-state electronics. A single energetic particle can flip bits in memory, damage transistors, or permanently degrade sensitive components. Engineers call this "single-event upset" — and in space, it's not a rare event.

Vacuum tubes, on the other hand, are naturally immune to these effects. Their operation depends on electron flow through a vacuum, not through a delicate silicon crystal lattice. There's no semiconductor junction to punch through, no charge storage to corrupt. That's part of why TWTs and other vacuum tube devices remain dependable in spacecraft — even decades after launch.

Sure, tubes are bulkier, require high voltages, and need careful handling. But when you're sending a billion-dollar probe beyond Pluto, reliability matters more than miniaturization. And in that arena, tubes still hold their own. ■ -editor

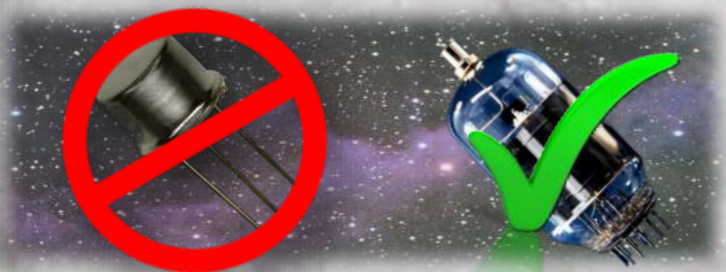
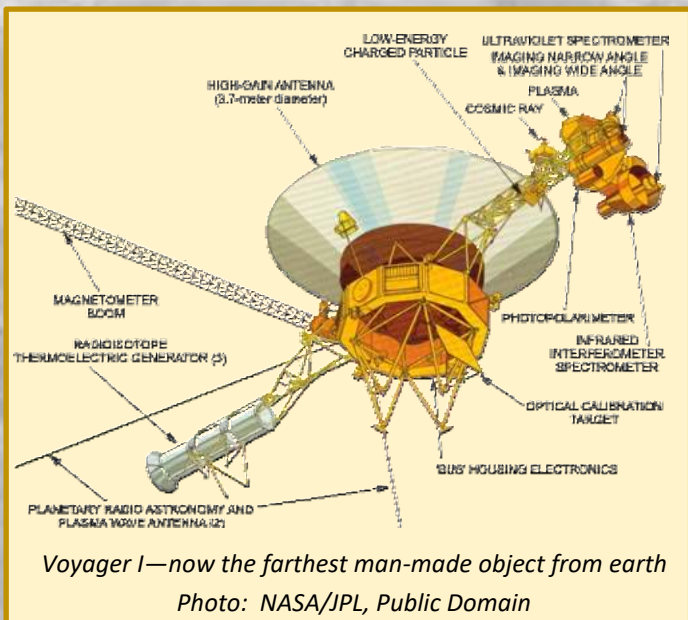

# STRAY TOPICS OF INTEREST:

## The MILKOTRON Tube!

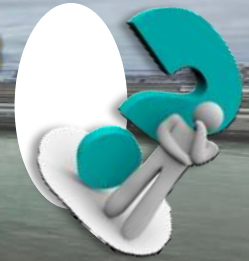

[Idea submitted by President Adam **W2NCC**—thanks Adam!]

**NO IT'S NOT THE APRIL ISSUE OF THE BARK BUT THE ORIGINAL** QST article about the “Milkotron” was an April fools joke not in the April edition but rather the [November, 1930 edition \(page 31\)](#). Feel free to read the linked article—it’s hosted at the Internet Archive. But in summary, it’s a funny satirical tale describing the fictitious “Milkotron” tube—in a tongue-in-cheek way with absurd pseudoscience that pokes some fun at overly complex technical explanations in ham radio.

Here are the key features and benefits of the Milkotron:

- Annihilates skip distance phenomena and fading signals
- Uses the reflecting power of the Milky Way instead of the Heaviside layer of the ionosphere
- Employs desiccated cow juice on the plate to control signal reflection angle
- Signal return distance can be specified: 100, 500, 1,000 miles—or “in a tail spin”
- Available in any capacity up to 100 quarts and any distance range desired or needed, ±5 miles
- Functions like a conventional vacuum tube, but with added dairy-based features
- Curdles when grid is negative; very positive when grid is positive
- Grid includes a “crooked” grid leak, reducing resistance
- Plate held in place by two false teeth embedded in the base
- Slightly decayed teeth emit a gas that lights the pilot lamp—no antenna meter needed
- Gas pressure regulates plate current, preventing filament burnout
- Also claims to relieve static-itus, halitosis, heartburn, and weak ankles



**THE MILKOTRON**

Photo: ©ARRL

Written by Woody Darrow, W3JZ, who describes his duties as “insulting engineer to the technickle staff of QST”. There is a graph in the article as well titled, “Big Chief Characteristics of Milkotron”. It’s a campy little article that should have run in the April issue for sure! If you want a laugh, click the link.

-Dave **W7UUU**

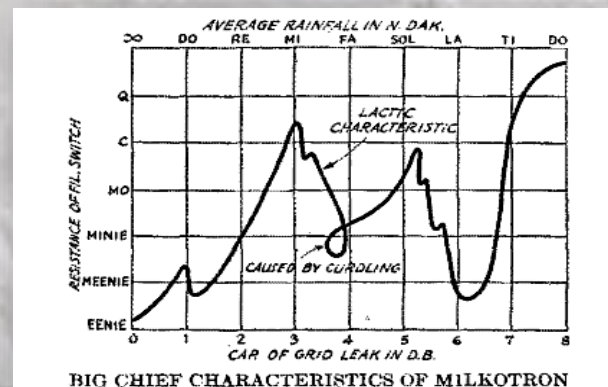

# RCT Bulletin Board

Posted notes and other important stuff

Here's a **useful tip** when reading the Bark: if you want to view a link, "right click" > "Open link in new window"... that way you won't lose your place in the Bark!

Stick it on your calendar NOW! **W7DK picnic location** is now booked—shelter #1 at Fort Steilacoom (same as years past) 8717 87th Avenue SW in Lakewood  
Date is **SUNDAY AUGUST 10th 11 to 3**

Last month's Hidden Object:



Regency Factory Page 121, far left

Last Month's Hidden Word:  
**LDMOS**  
It was hidden on calculator kit page 98



RETURN TO HOME PAGE





# Contest events for the coming month

**HUGE THANKS TO Mr. Bruce Horn, WA7BNM** for publishing his "Contest Calendar" for all these many years... a truly wonderful resource for finding virtually every ham radio contest on Earth that might be happening, in most any mode and most any region in the world. Follow the link to take you to the site, then sort through the various options to find the

specifics of every upcoming event. For now, here's the **WA7BNM** Contest Calendar for the this month. Click the calendar below to visit Bruce's site directly.



August 2025	
+ 10-10 Int. Summer Contest, SSB	0001Z, Aug 2 to 2359Z, Aug 3
+ European HF Championship	1200Z-2359Z, Aug 2
+ ARRL 222 MHz and Up Distance Contest	1800Z, Aug 2 to 1800Z, Aug 3
+ North American QSO Party, CW	1800Z, Aug 2 to 0559Z, Aug 3
+ Hemus VHF Contest - 144 MHz	0600Z-1359Z, Aug 3
+ SARL HF Phone Contest	1400Z-1700Z, Aug 3
+ ARS Spartan Sprint	0000Z-0200Z, Aug 5
+ WAE DX Contest, CW	0000Z, Aug 9 to 2359Z, Aug 10
+ SKCC Weekend Sprintathon	1200Z, Aug 9 to 2359Z, Aug 10
+ Maryland-DC QSO Party	1400Z, Aug 9 to 0400Z, Aug 10
+ SARL HF Digital Contest	1300Z-1600Z, Aug 10
+ 4 States QRP Group Second Sunday Sprint	0000Z-0200Z, Aug 11
+ SARTG WW RTTY Contest	0000Z, Aug 16 to 1600Z, Aug 17
+ ARRL 10 GHz and Up Contest	0900Z, Aug 16 to 0759Z, Aug 18
+ Keyman's Club of Japan Contest	1200Z, Aug 16 to 1200Z, Aug 17
+ North American QSO Party, SSB	1800Z, Aug 16 to 0559Z, Aug 17
+ CVA DX Contest, CW	1800Z, Aug 16 to 2100Z, Aug 17
+ NJQRP Skeeter Hunt	1700Z-2100Z, Aug 17
+ ARRL Rookie Roundup, RTTY	1800Z-2359Z, Aug 17
+ Run for the Bacon QRP Contest	2300Z, Aug 17 to 0100Z, Aug 18
+ NTC QSO Party	1900Z-2000Z, Aug 21
+ Hawaii QSO Party	0400Z, Aug 23 to 0400Z, Aug 25
+ YO DX HF Contest	1200Z, Aug 23 to 1200Z, Aug 24
+ Ohio QSO Party	1600Z, Aug 23 to 0400Z, Aug 24
+ CVA DX Contest, SSB	1800Z, Aug 23 to 2100Z, Aug 24
+ SARL HF CW Contest	1400Z-1700Z, Aug 24
+ SKCC Sprint	0000Z-0200Z, Aug 27
+ ALARA Contest	0600Z, Aug 30 to 0559Z, Aug 31
+ World Wide Digi DX Contest	1200Z, Aug 30 to 1200Z, Aug 31
+ U.S. Islands QSO Party	1200Z, Aug 30 to 0300Z, Aug 31
+ Colorado QSO Party	1300Z, Aug 30 to 0400Z, Aug 31
+ Kansas OSO Party	1400Z, Aug 30 to 2000Z, Aug 31



Click Calendar to visit online

WA7BNM Contest Calendar data used with permission

Background Image Source [LINK](#)

# THE W7DK ELMER BOARD

Do you have a skill or tool to help new hams?



**YOU! YES YOU!** Do YOU have a skill you could pass on to new amateur radio operators? Do you possess a skill or piece of gear that you're willing to share with others to fix antenna problems, diagnose noise issues, drive a ground rod, teach Morse, help teach technical topics? If the answer is YES you too could be a W7DK Elmer!! Let any

officer know what your skills are or how you could help new hams get a leg up on the hobby. And if you're one of those already on the list, are there any changes we should be aware of? If so please hit the email address (found bottom of page on the right) and let us know so we can update the W7DK Radio Club of Tacoma "Elmer Board".

**NEW HAMS OR MEMBERS:** If you are looking for help, and NEED AN ELMER to help guide your way, use this table! Find the skill you need on the left, then look for an Elmer Provider of that skill on the right and reach out to them. ALL of these Elmer's have committed to helping so please don't hesitate.

## ELMER ("MENTOR") BOARD

Do you need help with some area of ham radio?

**List of members' areas of interest:**

1. Technical questions, Classes
2. Help with Morse Code
3. License Examinations
4. Antenna and Station Planning
5. Antenna and Tower Erection
6. Buying Equipment (new or used)
7. Equipment Repair
8. Understanding and Using Your Gear
9. DXing and Contests
10. Club and ARRL Activities
11. Using Test Equipment
12. IRLP, Digital, SDR, APRS, WinLink, etc.
13. Basics of Electronics—how things work

**Name/Call Sign/Phone Number/Topic:**

- Adam **W2NCC** 360-870-7894 (4, 5, 6, 7, 11)
- Dave **N7HT** 253-363-1692 (1, 2, 4, 6, 8)
- Dave **W7UUU** (253-820-0890 (2, 4, 6, 9)
- Al **N7OMS** 253-495-9068 (10, 12)
- Mike **W7XTZ** 253-405-8095 (6, 8, 10)
- Stephen **AD7AB** 253-212-9437 (1, 3, 4, 12)
- Randy **WB4SPB** 253-761-9391 (2)
- Phil **K7PIA** 253-307-4781 (9, 10, 12)

Are you an RCT member with skills to offer?

Please let any officer know and we can add you!

Current as of January 2025

Variable Capacitor 2025

*Note: Providers or users of the Elmer Board must be local to the Radio Club of Tacoma. This is a local club service for our local members only. Thank you!*



# W7OS DOC SPIKE MUSEUM

## Featured Gear from the Museum



Photos & Text by Dave **W7UUU**

**LAST MONTH IN THIS SPACE I FEATURED THE** Heathkit HR-20 mobile HF receiver which debuted in 1962. The receiver it replaced is this month's Museum piece for discussion.

The Heathkit MR-1 "Comanche" receiver was introduced in 1959 as part of a coordinated mobile amateur radio setup, intended to pair with the MT-1 "Cheyenne" transmitter. Together, they formed a complete mobile HF station, aimed at amateur operators who wanted to operate Single Sideband (SSB) while on the road. This marked Heathkit's first serious foray into mobile high-frequency radio gear, and the MR-1 stood out for its sturdy design, flexibility, and surprising sensitivity.

Technically, the MR-1 was an eight-tube, single-conversion superheterodyne receiver that covered the 80 through 10 meter amateur bands. It could receive AM, CW, and SSB signals, with a reasonably selective IF strip and good stability for the time. It featured an RF amplifier, converter, two IF amplifier stages, a noise limiter, product detector, and dual audio stages. The internal design reflected an effort to maintain consistent performance even under the varying voltage conditions typical of automotive power systems.

The MR-1 measured a compact (for 1950s ham gear) 12 by 6 by 10 inches and weighed in at about 15 pounds, making it small enough to be mounted in a car but still pretty hefty by modern standards. It was typically powered by the optional MP-1 supply, which used then-new 2N442 transistors in a switching configuration—eliminating the need for a noisy mechanical vibrator (an electromechanical device that takes DC like from a car battery and converts it into pulses that can be fed to a transformer to generate high voltages).

This made the MR-1 especially appealing for mobile operation, where clean power and compactness were valuable assets. When it debuted, the MR-1 sold as a kit for \$119, a reasonable price for a high-performance receiver at the time.



Heathkit MR-1  
Mobile Receiver—W7OS collection  
Photo by Dave **W7UUU**

Though it is largely a collector's piece today, the MR-1 still represents an early milestone in serious mobile ham radio design. Its practical circuitry, rugged construction, and beautiful Heathkit styling continue to appeal to collectors and boat anchor fans. Next month I will feature the matching transmitter, the MT-1 "Cheyenne" which also resides in the W7OS Doc Spike Museum at the Radio Club of Tacoma.

—Dave **W7UUU**



**THE *New* ELMAC PMR 6-A RECEIVER**  
*Designed by Amateurs... for Amateurs!*

**PORTABLE MOBILE RECEIVER - 6 BANDS A (AMATEUR COVERAGE)**

Here is a complete 10 tube, dual-conversion, communications receiver that packs more performance and value into a six-inch wide cabinet than anything you've ever seen! Engineered and manufactured by the makers of the famous ELMAC, all-band mobile transmitters, the PMR-6A is a six band (INCLUDING BROADCAST) receiver designed for either mobile or fixed station use. You now car buyers will want to include this receiver in the deal. It will be your car radio supreme... from now on! Compare these specifications and then order your ELMAC PMR-6A from your nearest dealer.

- 6 Bands
  - (1) 550 kc to 2000 kc (Frequency and 500 meter band)
  - (2) 2.6 to 4.0 Mc (10 and 20 meter band)
  - (3) 6.7 to 7.3 Mc (40 meters)
  - (4) 11.2 to 11.45 Mc (100 meters)
  - (5) 20.55 to 21.45 Mc (1.5 meters)
  - (6) 28 to 30.2 Mc (100 meters)
- Dual Diodes and all covered tubes 1955 to test I.F. 455 kc vacuum X.F.
- Top board chassis provides true linearity.
- Built-in night vision neon beam.
- Built to Best Frequency Oscillator.
- Full 3-A wavy beam output with less than 1 mamp. efficiency.
- Tuned A.F. band at converter on all bands.
- Volume regulated to avoid oscillation, BFO, and audio converter.
- Temperature compensated neon tube oscillator tube has high memory.
- Block base ground dial cable full wire; but does not wind the dial operator at night.
- KVC "on-off" switch located on front panel.
- Antenna relay delivers to match 50 ohm coax
- Power requirements: 5 watts A.C. or D.C. at 5:9 impedance.
- 29 watts O.C. at 90 ohm impedance.
- Power supplied partially for 6 and 12 V.D.C. or 115V AC
- Control Switches (a gray base model size 497" H. 7" W. 4 1/2" Gm)
- Weight: 6 1/2 pounds.
- Size 10 tubes:
  - 1-1813A F. Amadler
  - 1-6815 First Converter
  - 1-224 I. last Oscillator
  - 1-6815 Second Converter
  - 2-6820 First and Second I.F. Amadler
  - 1-6825 Neon tube and Neon Lighter.
  - 1-1247 First Audio and S.F.D.
  - 1-6835 Audio Output
  - 1-6027 Preamp Regulator
- Price: \$139.50

**A WHILE AGO** Chuck AC7QN, gave me an old Elmac PMR-6A mobile receiver from around 1952. The case was badly rusted. The plastic dial cover was warped, cracked down the middle, yellowed, and barely transparent. After moving into our current house four years ago, the PMR6-A somehow escaped its moving box and ended up on the floor of our family room. After stepping over it for several years, I finally placed it on the workbench for a closer look.

For the first time ever, I removed the top and bottom covers. Much of the outer case was very rusty. Inside, it looked like dried rusty mud had turned to powder. To me, it seemed like it could have been pulled from the bottom of a stream. But Chuck said he found it on the Radio Club of Tacoma's clubhouse Free Table.

**SINCE IT'S ALREADY ON THE BENCH**—and I had a high-voltage power supply, croc-a-gator leads, and a speaker nearby—I was intrigued. The schematic I found online showed that the PMR6 needed either 6 or 12 volts for the vacuum tube filaments (both voltages common for cars of that era). The dial lamps are type #1813 which are 12V, according to an old ARRL Handbook. Following the schematic's connection notes, I applied 12VAC and +230VDC to the rear apron's octal plug. (Normally, the mobile power supply's umbilical cable would connect here.)

An encouraging result followed: I heard radio noise from the speaker. But when I looked inside, not all the tubes were glowing with that familiar orange filament light. According to the schematic, two 6V tubes are wired in series for the 12V filament supply. I pulled the dark tubes and checked their filaments with a meter. I also noticed a film of dried muddy residue on top of the sockets. The filaments tested fine, and after reseating the tubes—success!—they all lit up. As one YouTube expert says, "65 years of corrosion makes for poor connections."

**PROLOGUE:** This story of an old receiver restoration was originally written as a series of blog entries—in email form—titled "A Story in 2.5 Low Rez Photos." I sent it to a few fellow hams who I thought would be interested. Dave W7UUU, Editor of the *Bark* newsletter, encouraged me to turn those entries into a proper article. What follows is that attempt, based on the original blog.



**LET'S CLEAN SOME CONTACTS:** I moved the PMR6 to the garage worktable. I sprayed WD-40 brand electrical contact cleaner (no not the lubricant, and yes, it exists, and yes, Home Depot carries it) into each rotary switch and the volume control. I followed the classic “spray and rotate, rinse and repeat” method. I pulled and reseated each tube after spraying its socket. Then I used an air compressor to blow out cobwebs and caked-on grime. Finally, I applied a small drop of bicycle chain oil to each moving metal part. With that, the PMR-6A went back to the workbench.



*The dusty rusty crusty inside of the PMR6-A, with the tubes aglow*

I started with Band 1, which covers 160 meters and the AM broadcast band. No local AM stations were heard. So I connected an S-9+20dB test signal at 1.8 MHz from a signal generator to the antenna jack. Still nothing.

### **INTERNET EXPERTS SAY:**

When troubleshooting a receiver, they advise starting at the speaker and working backward toward the antenna. I heard variable noise at the speaker that responded to the volume control, which meant the audio section was working. Next in line was the 455 kHz second intermediate frequency (IF) stage. According to the manual, a tone-modulated 455 kHz signal should be applied to the rear-most section of the variable capacitor. I did just that—and Yreka! The tone came through the speaker. I then adjusted all the IF transformers of that stage for maximum loudness.

**SLOGGING UPHILL:** Moving further back in the signal path, I switched to Band 2 (80 meters) and fed in a 1600 kHz modulated signal (the first IF is 1600 KHz). Again, nothing came out of the speaker. According to the manual, Bands 2 through 6 use an added IF stage, making the receiver “double conversion.” This design improves selectivity and sensitivity. I carefully followed all procedures and double-checked everything. I was 95% sure I had done it by the book. Time for a break.



*WD-40 brand electronic contact cleaner*



**SCHEMATIC RETHINK:** I revisited the schematic. I couldn't understand how the test signal could reach the IF chain through the switch path as described. It looked to me like the signal should be applied to the *second-to-last* capacitor section, not the last. I made the change—and Yreka! The tone came through. I performed the alignment on that IF stage without issue.

**FURTHER UPHILL TO THE ANT:** The final alignment instructions called for switching back to Band 1 and feeding a 1800 kHz modulated signal into the antenna jack. As I tuned around, Yreka! I could hear local AM broadcast stations. Apparently, the signal generator was acting as an antenna. With Band 1 working, I moved on to Bands 2 through 6. I peaked the tuning circuits for maximum sensitivity and dial accuracy. This receiver has about 40 alignment points—coils and capacitors—and they're packed closely together. It's easy to adjust the wrong one if you're not careful.

**THE TRIFECTA YREKA:** Still amazed that this dusty, crusty, rusty old radio was coming back to life, I connected my QTH's 20–40 meter fan dipole. On 20 meters, I easily heard SSB signals, followed by CW. Most impressively, the dial was very accurate when checked against the FT-8 frequency standard (14.074).

Although the PMR-6A was designed for CW and SSB, I wanted to test its AM reception. That evening, I tuned to the top of the 40-meter phone band and clearly received two loud AM nets. In 1952, AM was still the dominant voice mode; SSB didn't really start to catch on with hams until 1955 or 1956.



*The PMR-6A dial face before refurbishment*

**BUT IT'S STILL UGLY:** No argument there. The dial cover was warped and cracked in two. The bezel around the knobs had warped, too. I epoxied the three pieces back together using woodworking clamps. Then I cleaned and polished the scratched and grimy plastic using a [three-step Novus plastic restorer kit](#). According to old PMR-6A photos online, the plastic had a factory-applied yellow tint, so the color checks out.





## Where sick radios come back to health

**SO WHAT DID I REALLY FIX?** You may be wondering. Fortunately, the PMR-6A was in decent internal condition. I replaced only two electrolytic capacitors in the audio section. They may not have been bad, but 70-year-old electrolytics are always suspect in restorations. My best guess? Cleaning the contacts—especially the tube sockets, band and

mode switches, and the volume control—was what really brought the set back to life.

I gave the rusty chassis a light sanding, masked it off, and applied a few coats of Behr gray spray paint. It now looks a lot less tragic. I also added rubber bumper feet to the bottom cover.



*The completed Elmac PMR-6A receiver with repainted cabinet and restored faceplate*

*All photos in this article by Rich KR7W*



The PMR6-A was Elmac’s first ham-band receiver. Its companion CW/AM transmitter is the model A54, made in the same 1952–53 era. It puts out 25–30 watts using a well-charged car battery. As I write this, I’ve just bought an A54 on eBay—described as “it worked 10 years ago”—and it’s on its way.

**EPILOGUE:** This restoration was a different experience for me. Usually, I test all the tubes and replace every out-of-spec resistor and paper cap. This time, aside from the two electrolytics, I didn’t replace a thing.

It’s probably obvious that I’m a fan of Elmac gear. In my boat anchor collection, I also have an Elmac [PMR-8 receiver](#), its matching [AF68 transmitter](#), and the original mobile power supply—the final AM-only ham rigs Elmac produced. I secretly dream of owning a 1957 Ford Galaxie, mounting my Elmac gear under the dashboard on the driveline hump, and cruising down the highway with a CB whip antenna, operating mobile at the top of 40 meters.

But for now, listen closely (very closely) for my 30–40 watt Elmac boat anchor rigs from my home QTH during the upcoming Classic Exchange on-the-air event.



To hear a 1-minute audio file of the PMR-6A receiving 40m SSB, just right-click the above image and “Open in new tab”

This was a rewarding project bringing this dusty rusty crusty radio back to life for the first time in a lot of years. It’s always fun to ponder how these old rigs spent their youth, adult years, and finally their retirement. All we ever really know is how it all came to an end... a SK estate pile O’Gear that got delivered to the DK clubhouse sometime in the past, with the Elmac ending up on the free table after no one felt like it was worth buying.

As always, thanks for reading this far.

Best regards—Rich KR7W

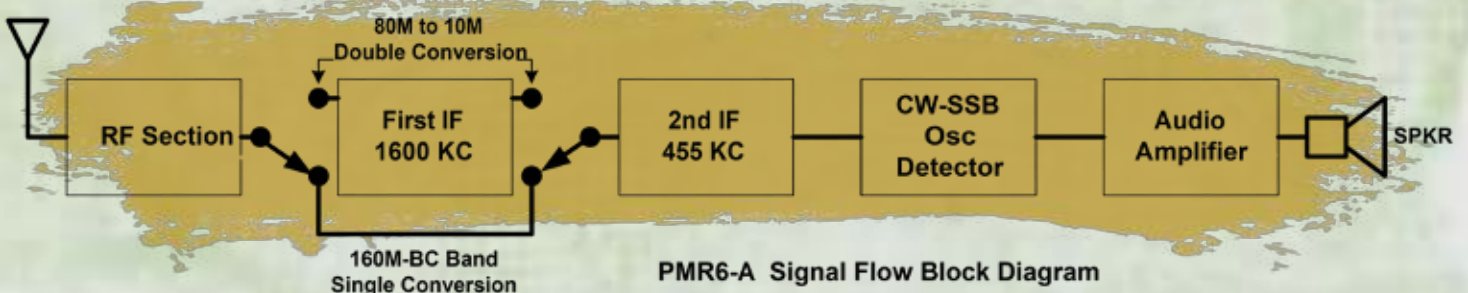

PMR6-A Signal Flow Block Diagram



**WHEN A GROUP OF RADIO OPERATORS BEGIN CALLING “CQ INTERNATIONAL DOG DAY” IN AUGUST, THEY’RE NOT JUST LOOKING FOR QSOs...**

**They are in search of people who have room in their hearts** to help the abandoned, abused and homeless dogs around the world in whatever way they can. These dozen or so special event operators know the power of rescue because they’ve been deeply involved in it themselves: Hanz **YL3JD** and his wife opened their home – first in Holland, later in Latvia – and have given needy dogs a second chance at a new family. In Australia, and later in Germany, Ed **DD5LP** and his wife discovered – several times – that their household was incomplete without canine company. Many of the other operators’ rescued dogs were adopted after hard lives on the street; others were at the pound, hours away from being euthanized.

International Dog Day (and in the US, National Dog Day) is August 26 every year. The tradition was created by US pet advocate Colleen Paige as a day to recognize the needs of society’s unwanted and cast-off dogs and affirm the commitment to adopt, donate or raise awareness of their special needs.

**Hanz amplified the original message** by adding an amateur radio component in 2022, taking the special-event callsign **YL1DOG** and operating as a single station. The following year he was joined by Chris **G5VZ**, and David **G4YVM**, in the UK. By 2024, a team of eight US rescue-dog advocates, operating as **K2D**, had



come on board. This year is the biggest yet, as hams in Germany and other countries run with the pack. All

operators will be looking to hear from dog-lovers and supporters in either CW or SSB on HF, on VHF/UHF simplex, or via DMR and EchoLink.

**The international team has added incentive certificates**, including special endorsements such as “Full Kennel,” the equivalent of a clean sweep. Their website, [www.dogdayradio.org](http://www.dogdayradio.org), is updated regularly with the operators’ special-event callsigns, their operating schedules, a chance to meet the dogs who inspired them and hear their stories.

In case you are wondering where the *cats* are – well, they’re running ahead of the dogs! International Cat Day will be operating as a separate event, two weeks before the Dog Day operators get on the air – and they will be carrying a similar message for cat-rescue awareness. See [catdayradio.org](http://catdayradio.org) for details.

**For live updates of both events**, to search for the different callsigns, to see the operators’ schedules or to apply for and download award certificates visit these links when they become available:

	<a href="https://hamlog.online/icd">https://hamlog.online/icd</a>
	<a href="https://hamlog.online/idd">https://hamlog.online/idd</a>

Meanwhile, be aware that all special-event operators will be working like dogs – and why not? – because they want to hear and share as many rescue stories as they can.

-Caryn **KD2GUT**



Brian **K3ES**’s Boston terrier Molly



Hanz **YL3JD**’s dogs in Latvia—Buča on the left, Sissi on the right

# STRAY TOPICS OF INTEREST:

Try out a PRC319  
"Manpack Transceiver" for free\*



Contributed by Paul WØRW

## TRY OUT A PRC319—FREE\* BACKPACK RADIO LOANER NOW AVAILABLE!

Ever wanted to get your hands on a [PRC319](#)? Now you can. One of these legendary backpack HF rigs is available on free loan to any licensed ham in the lower 48.

Whether you want to test it in the field, show it off at a club meeting, or just finally see what all the fuss is about—this is your chance.

Not familiar with the 319? It's a rugged, fixed-frequency, channelized HF radio originally built for military use. It's channelized—no VFO—just punch in a channel and go. It runs CW, USB voice, or data at either 5 watts or a full 50 watts. You can watch a great overview video at [THIS YOUTUBE LINK](#).

You can read more about the [PRC319 HERE](#).

**The loaner comes as a complete kit:** PRC319 radio, antenna tuner, handset, battery/AC supply, and satchel. Due to the battery, it ships *UPS only*.

### Here's how this program works:

If you want to borrow it, drop me a line and I'll send you the loan agreement. When your turn comes up, I'll let you know. You'll send upfront \$100 to cover shipping out, and you'll be responsible for return shipping too—figure around \$200 total. You get to keep it for up to 90 days.

Sorry—CONUS *only*. No shipments to Alaska, Hawaii, or Puerto Rico. You'll need a General class or higher license and must appear in the FCC database.



*This is the actual PRC319 "Manpack transceiver" that is available to borrow for up to 90 days (continental U.S. only).*

This unit was donated by Clare Owens Jr. [N2RJB](#), of Apex, NC. Accessories came from Al [G8LIT](#). Thanks to both for helping make this possible.

**Interested?** Reach out to Casey Efav [KD2YMM](#)  
[KD2YMM@gmail.com](mailto:KD2YMM@gmail.com)

Information provided via [WØRW](#)

\*Just pay shipping both ways. Disclaimer: Neither W7DK nor Editor [W7UUU](#) have any direct involvement in this offer. All details of the transaction and transfers of the radio are solely between the borrower & [WØRW](#) & Casey

# WWII POW CANTEEN RADIO

By W7UUU

## THE CANTEEN RADIO: WARTIME INGENUITY IN CAPTIVITY

Some of the most remarkable stories from the Second World War didn't take place on the battlefield or in the cockpit, but in far more unlikely settings. One such story that I recently became aware of unfolds not in a command post or a communications van, but inside a Japanese prisoner-of-war camp in the Philippines—where a tube-based regenerative shortwave radio receiver was covertly built inside a standard-issue U.S. Army canteen.

**The individual responsible for this feat was Captain Russell J.**

**Hutchison** of the U.S. Army Signal Corps, a trained radio man and licensed amateur operator (with the call sign **W6ZH**). Following the fall of Bataan in 1942, Hutchison became one of the thousands of American and Filipino servicemen imprisoned at [Cabanatuan](#). The conditions as you can image were brutal, with overcrowding, disease, starvation, and not much hope of escape or

rescue. In such a place, any connection to the outside world was at once nearly impossible but potentially even life-saving.

**Nevertheless, Hutchison managed to construct a working tube-operated regenerative shortwave receiver** using scavenged parts and improvised tools. What made the effort even more extraordinary was the method of concealment—he housed the entire radio inside an empty military canteen. The old-style aluminum model, not the plastic variety familiar today,

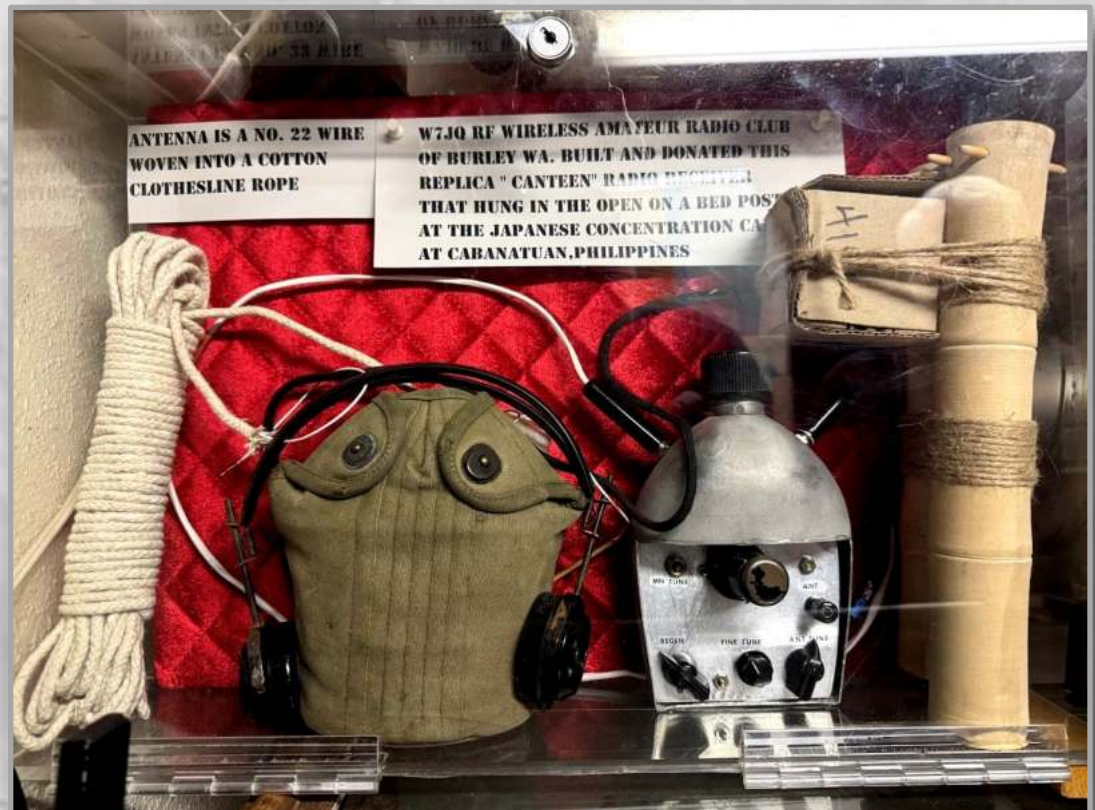

*Beautifully rendered replica of the canteen radio receiver built by **N7CFI** of the Burley, Washington Radio Club W7JQ. It is on permanent display in the Veterans Living History Museum at [825 Bay Street in Port Orchard, Washington](#). Admission is free (donations gladly accepted).*

*Photo by Dave **W7UUU**. Thanks to Tom **N7CFI** for providing the construction details.*



# WWII POW CANTEEN RADIO

By W7UUU

provided just enough space to hold a single metal-shell [12SK7 radio tube](#), and the small handful of parts to make a working regen shortwave receiver. The whole thing including jacks for the antenna and external batteries was well concealed to avoid detection by the guards.

**The design itself was basic but efficient.** At the time it would have been completely conceivable that the schematic could be drawn out from memory. Hutchinson used a 12SK7 pentode to build the receiver. Even a very simple regen like this can have amazing

attracting attention. It just looked like a clothesline.

**So how was it powered?** Some of the reports I researched on this say the power to run the receiver (12v for the filament of the 12SK7, B+ of 90v or more), derived somehow from an AC outlet that Hutchinson accessed in the Catholic chapel. But of course that would have required a power supply to convert mains power to that needed for B+, and the 12v for the filament.

Another reference states they used battery power

that was available in the prison hospital. Still other sites I found claim that Hutchinson “smuggled in batteries stolen from around the camp”. That to me seems a much more plausible story—the tube only needed 25 to 90 volts and that could easily be achieved using batteries linked in series. I will leave it to the reader to research further—I simply was not able to find a single confirmed “actual factual” answer.

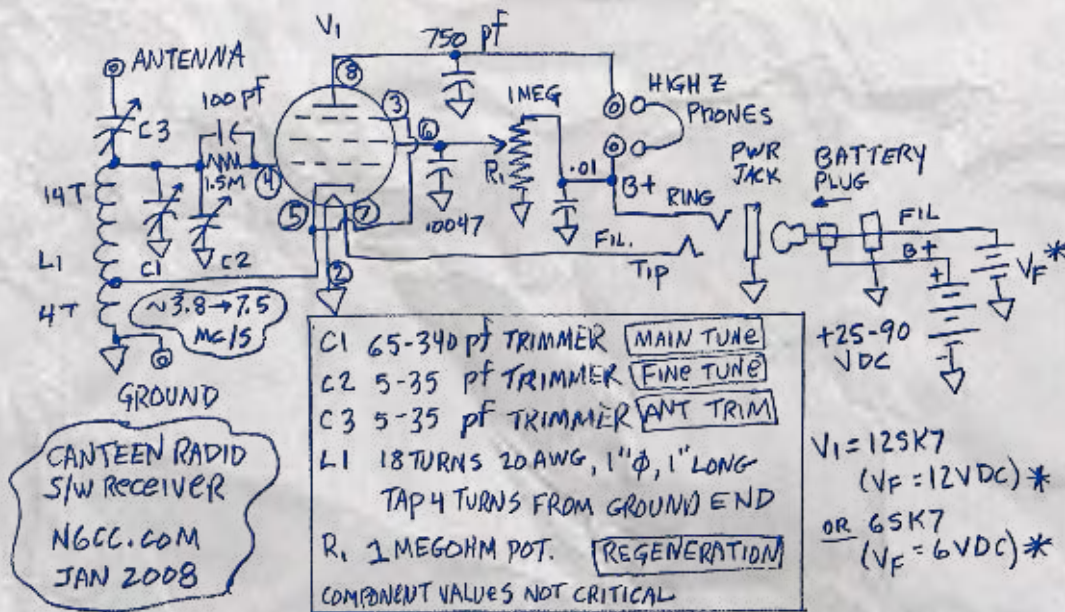

This is the 2008 schematic created in 2007 by Tim J. Sammons, N6CC, for his replica of the POW canteen receiver. This is the schematic used by many recreators of this project, including the one featured on the previous page that is on display VLH Museum in Port Orchard. Image © N6CC

reach on the shortwave bands, with a suitable antenna. Just such an antenna was fashioned from a fine wire threaded laterally through a cotton laundry line, a clever disguise that allowed reception without

**Regardless of how it got its power**, the radio worked well. It pulled in broadcasts from the BBC, Voice of America, Radio Australia, and the so-called “Voice of

# WWII POW CANTEEN RADIO

By W7UUU

Freedom”—a Filipino-American resistance station transmitting from the mountains on 666 KHz AM with the [call sign KZRH](#) (later becoming DZRH which the station still holds today).

**For the prisoners, these reports provided critical news** that Allied forces were still fighting and making progress in the war. While morale in the camp was dangerously low, the radio's updates offered renewed hope—and in some cases, helped inform decisions that would ultimately save lives.

The risks involved were *enormous*. Possession of a radio was strictly forbidden and punishable by execution. Japanese guards conducted frequent inspections, often searching for contraband or evidence of resistance activity. Yet Hutchison and a handful of trusted fellow prisoners managed to keep the radio concealed through multiple searches, at times hiding it beneath floorboards or in plain sight among other canteens. That it was never discovered is a testament both to their caution and to the clever effectiveness of the canteen's disguise.

**After the war, Hutchison survived and returned home.**

In later years, his story became known through his family and a few dedicated radio historians. Perhaps the most detailed documentation comes from Tim Sammons ([N6CC](#)), who researched the project extensively and built a faithful working replica using period components. [Here is a link to his documentation.](#)

Tim's recreation, including photos and schematics, is now on display at the [Veterans Memorial Building](#) in Danville, California. In researching this article, I've

learned there are quite a few replicas that have been built.

And that is in fact what brought me to learn about the Hutchinson Canteen Radio. In addition to W7DK, I'm also a member of the Burley (WA) Radio Club, W7JQ. In chatting with Burley member Lynn [WR7G](#) one day, he told me that another member, Thomas [N7CFI](#), had built a replica himself, that is now on display at the [Veteran's Living History](#) Museum located at 825 Bay Street in Port Orchard, Washington. One day in late May, Thomas and I visited the tiny museum and I met the curator, Dale Nitz. He runs this amazing museum entirely on his own dime and through the generous donations of visitors.



*Visitors will know instantly, just driving by, if the museum is open. Every day Dale is open he painstakingly and lovingly arranges a wide assortment of artifacts right in front of the building on the sidewalk. Remember that this is a museum and not a store, so none of the items are for sale.*

*Photo by W7UUU*

# WWII POW CANTEEN RADIO

By W7UUU

**It was Dale who commissioned the Burley club** a few years ago to build him a replica, which is on display at the rear of the museum.

At first glance, the canteen radio looks like little more than a dented piece of military surplus. But beneath that exterior lies an amazing tale of ingenuity and hope. It represents not just an extraordinary act of technical improvisation, but a quiet form of defiance. In a place where prisoners were stripped of nearly everything—freedom, dignity, even the certainty of survival—this little regen receiver reestablished a link to the outside world and helped restore a sense of humanity to the servicemen imprisoned there.

**I would highly encourage anyone reading this** who is anywhere near to Port Orchard—please—take some time to stop by. Dale is there several days a week and you'll know the museum is open as he sets up ever-changing displays of memorabilia right in front on the sidewalk. Just be aware: it's a *very narrow* space but is packed full of amazing artifacts. Dale is a great curator and can tell you stories about pretty much every single item in the museum.

-Dave W7UUU



*The VLH Museum is very deep but also very narrow. Generally, it's single-file but visitors work it out. The dog is friendly!*



*The Canteen radio is all the way at the back on the right, in a display case. It's very well lit. Photos by Dave W7UUU*

# THE WAY BACK PHOTO BOOTH

Highlighted photos from the club's past

*Researched & Compiled by the Dave W7UUU*



Archive Photo



**IN 1971 THE RADIO CLUB OF TACOMA LAUNCHED** what would become a long-standing tradition: the W7DK Silent Keys board. This of course was to list the names and call signs of members who have passed away.

The photo above shows Dr. Clifford J. "Doc" Spike, W7OS, examining the first such board to be installed in the clubhouse. For those that remember Dymo, you will recognize the name listings on the board were made using a Dymo plastic tape embosser. Clearly not the most permanent solution, and it wasn't long before the stickers likely started falling off. At some point, the club converted over to commercially-made engraved plastic tags, which is the method used to this day.

Currently there are three such boards now gracing the walls of the clubhouse classroom—a testament to the many generations of hams who have walked the halls of the Radio Club.

Sadly the boards have not been updated in some



time, and there's even talk of removing the boards to free up the wall space. That would be a sad day in my opinion, and the loss of another long-standing club tradition, but as we used to say "that's progress" - so time will tell.

Next time you're in the clubhouse, take a moment of silent contemplation and read some of the names remembered on these remembrance boards.

*-Dave W7UUU*

# MIGHTY DK! QSO REPORT

Reporting all the HF QSO action from the club



W7DK

**EACH MONTH** in the Bark, the Radio Club of Tacoma recognizes the members and guests who have made non-contest QSOs using the HF stations at our clubhouse. [Saturday Open House](#), especially, is a time when members have access to this equipment. Why not sit down at one of our operating desks and make a contact or two? Assistance is almost always available for those unfamiliar with the equipment, and if your license class doesn't permit HF operation, ask the denizens of the HF Room or the Saturday clubhouse host to help you find a suitably-licensed control operator to sit with you. It's a feather in the club's hat for the call sign of The Mighty DK to be heard on the airwaves. So get on the air and get your name in the Bark! (Don't forget to *enter your call sign as the operator* into our logging program.) ■ -editor

**Clubhouse QSOs during this period:**

NAME	CALL	QSOs
Mike	W7MKE	63
John	K2CCT	22
David	W7GEL	13
Gary	WG7X	9
David	AC7KP	6
Julie	W7JUL	3
Leah	K7IPT	3



**Above:** HF Room Flex 6600 & Mercury III

**Below:** HF Room Icom IC-7610 & KPA-500



Photos this page provided by  
Dave **W7UUU**

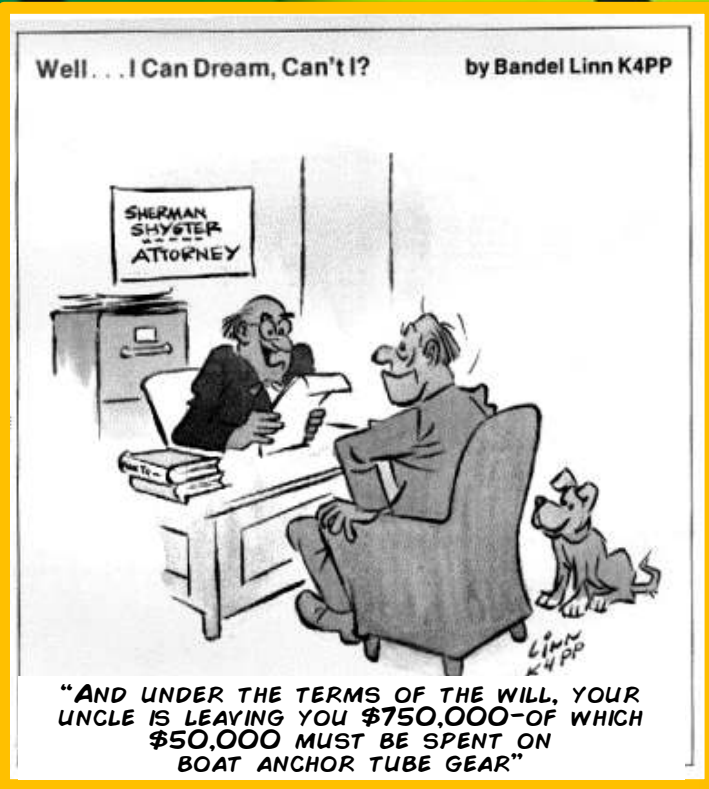
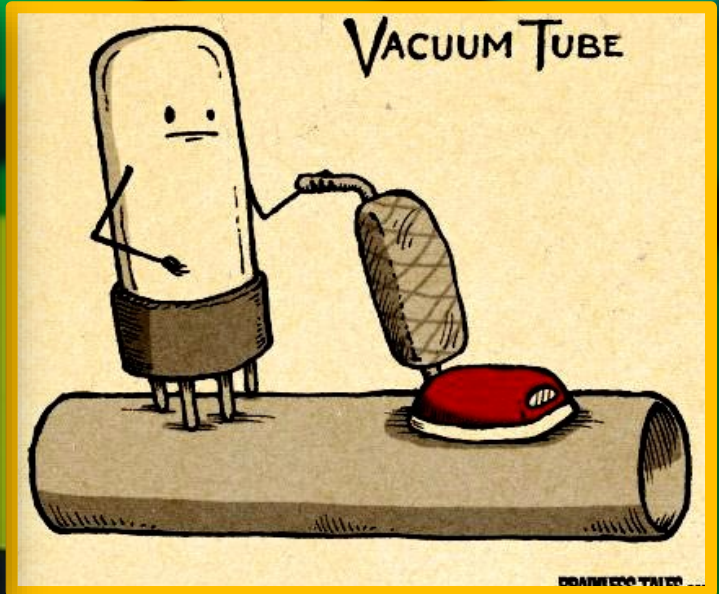



# HOW'S DX?

DXpeditions and Notable DX operations

WEB

## NG3K Upcoming DXpedition Calendar



August		NG3K	NG3K	NG3K	NG3K	NG3K
2025 Aug02	2025 Aug08	Ogasawara	<a href="#">JD1BRC</a>	JH7CSU	<a href="#">OPDX</a> 20250605	By JH7CSU fm Higashi-machi, Chichijima; HF; mainly CW
2025 Aug02	2025 Aug10	Mayotte	<a href="#">TO3K</a>	LoTW	<a href="#">DXW.Net</a> 20250613	By IV3JVJ IK3ZAQ IZ3NYS fm IOTA AF-027; 80-6m; CW SSB FT8 FT4; 100w; QSL via IV3JVJ
2025 Aug03	2025 Aug18	South Cook Is	<a href="#">E51KEE</a>	LoTW	<a href="#">DXW.Net</a> 20250623	By ZL2KE fm Rarotonga I; 40-10m; CW SSB; QSL via Club Log OQRS or IK2DUW
2025 Aug08	2025 Aug11	Br Virgin Is	<a href="#">VP2V</a>	LoTW	<a href="#">TDDX</a> 20250626	By KK4LWR as VP2V.KK4LWR and KD8RTT as VP2V/KD8RTT fm Tortola I; HF, focus on 6m; 100w; QSL via home_call direct
2025 Aug15	2025 Aug29	Greeland	<a href="#">OX</a> <small>NEW</small>	DL6YYM (B/d)	<a href="#">DXW.Net</a> 20250705	By DL6YYM as OX/DL6YYM fm IOTA NA-134 (Aug 15-18) and NA-018 (NA-018); HF; CW; QRP
2025 Aug16	2025 Aug23	Guatemala	<a href="#">TG4</a>	LoTW	KT8X 20250627	By KT8X as TG4/KT8X; 40-6m; CW + digital; holiday style operation
2025 Aug17	2025 Aug25	Dodecanese	<a href="#">SV5</a>	LoTW	<a href="#">OPDX</a> 20250625	By N3JWJ as SV5/N3JWJ fm IOTA EU-001; HF; FT8; QSL via Club Log OQRS
2025 Aug18	2025 Aug22	Palau	<a href="#">T8</a>	LoTW	<a href="#">DXW.Net</a> 20250425	By JH6GFY as T88GF and JK6DXD as T88XD; HF; QSL via JH6GFY and JK6DXD respectively
2025 Aug18	2025 Aug23	Chile	<a href="#">3G1P</a>	Club Log OQRS	<a href="#">TDDX</a> 20250520	By VE3LYC XQ7IR PA3EXX fm Ilotes Pajaros (SA-100 New); 40-10m; CW SSB; see Web for QSL details

Click anywhere on the table above to visit Bill's site directly—the hyperlinks will be active there.

Courtesy Bill Feidt, **NG3K**  
used with permission

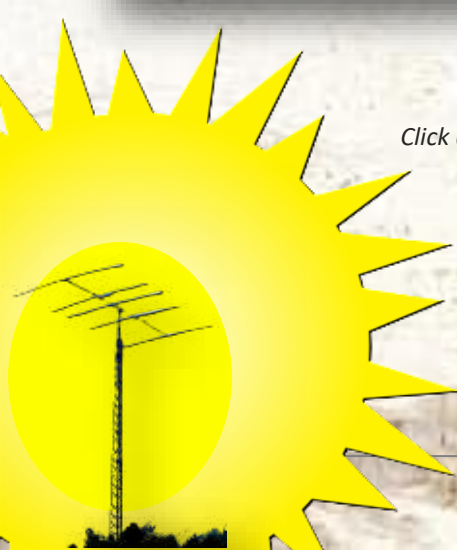

# Homebrew & Kits corner

## THE MICHIGAN MIGHTY MITE RIDES AGAIN!



A FEW YEARS AGO, JUST FOR FUN, I BUILT THE MICHIGAN [Mighty Mite one-transistor transmitter](#). It only took about three hours—including the time I spent digging through my junkbox for parts. It put out around 300 mW using the only 20-meter crystal that I had—14.318 MHz. Still, I managed to work a CW station about ten miles away.

Recently, while poking around eBay, I came across a modern take on the concept—this time based not on a transistor, but a single 6C4 tube. It’s designed and sold by Grayson Evans, [K7JUM](#)—author and well-known Thermantron (tube) guru. See my photo & mention of his book on page 101 in this issue of *The Bark*.

What makes his kit unique—aside from using a tube—is that you’re essentially homebrewing it from a curated pile of parts. There’s no pre-drilled circuit board or



Complete TMMM 1-tube kit of parts as received

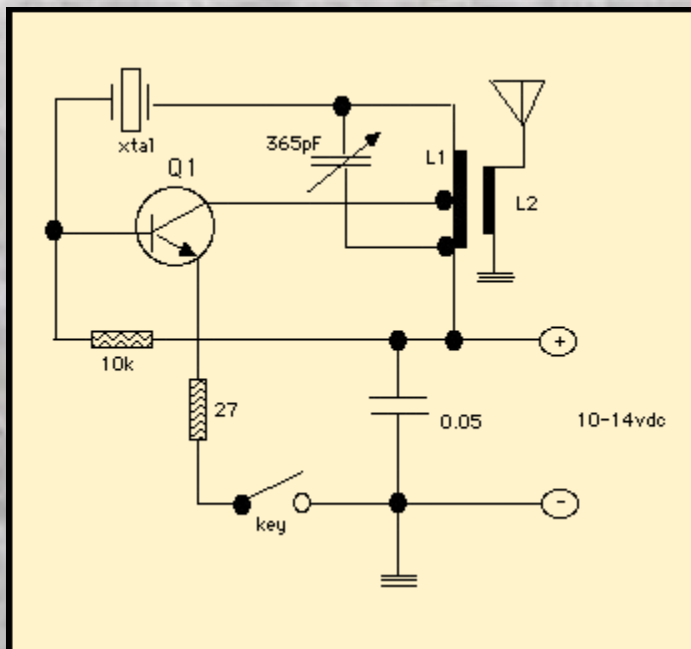

Schematic of the 1-transistor Michigan Mighty Mite  
Built version is on the right



My original Michigan Mighty Mite 1-transistor  
20m CW transmitter from a few years ago  
Photo by Dave [W7UUU](#)

# Homebrew & Kits corner

## THE MICHIGAN MIGHTY MITE RIDES AGAIN!



fancy packaging. You get a blank PCB, all the necessary components, a handmade panel for mounting the BNC and RCA jacks, and a clever little device called a [Me-Tube panel](#) that you superglue to the PCB for soldering the tube and other parts. You also get [MeSQUARES](#)—glue-on pads made from PC board material that function like terminal strips.

Building this kit doesn't feel like a kit at all—it feels just like homebrewing from scratch. And it's simple to put together. Aside from the tube and crystal, there are only two fixed capacitors, a tiny variable cap, and a resistor. That's it.

Output is about 300 mW using my existing power supply. Note that Grayson's [eBay listing](#) shows a green PCB

power supply claiming to be a 420V buck converter that takes 12VDC and spits out the high voltage this little rig needs. I strongly advise *against* using that board. See the article on page 98 for full details. I bought one, and it was terrible—just as most of the Amazon reviews warned. I used a homebrew supply instead.

Elsewhere in this issue, you'll find more info on the Me-Tube panels, MePads, and the specific tube socket used.

Next month, I'll share a full report on how the TMMM transmitter is performing—and hopefully have a few solid QSOs to brag about. Until then, 73 and thanks for reading.

—Dave W7UUU

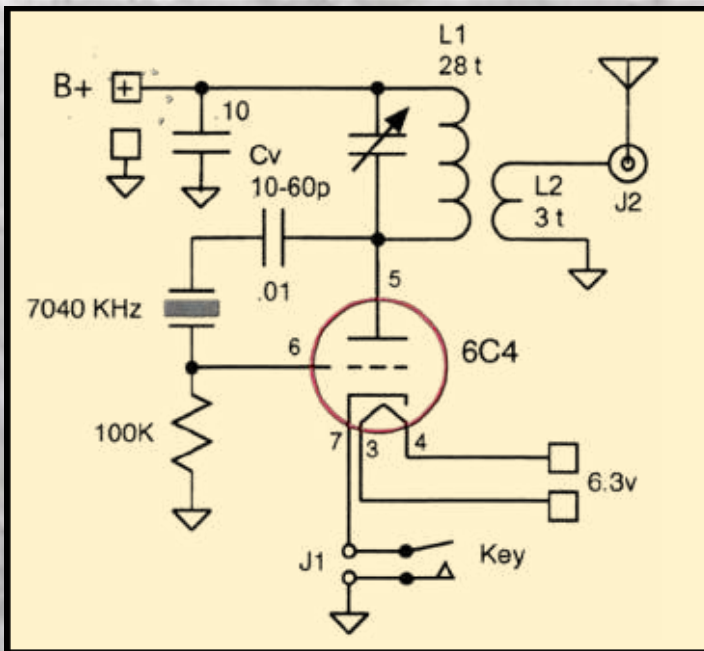

Super-simple schematic of the TMMM 1-tube transmitter kit. The model number TMMM stands for "Tube Michigan Mighty Mite"



Finished TMMM 1-tube transmitter kit. The yellow wire is soldered to MeSQUARES. Photo from the [eBay ad](#)

# Homebrew & Kits corner

## ANTIQUÉ WIRELESS ASSOCIATION

### 6AQ5 TRANSMITTER PCB



**ANOTHER FUN ENTRY VERY SIMILAR TO THE PRECEDING** kit is the PC board sold by the Antique Wireless Association for \$16.50 including shipping. *But do note: this is not a kit! You only receive the circuit board and you then source all of the parts yourself.*

So similar to the preceding transmitter “semi-kit” the AWA transmitter should be a fun build, in the sense you will have to dig in your own junk-box to find the needed parts. Or make it something of a scavenger hunt for the next hamfest. As you wander the aisles, you have the challenge of digging in the corners of boxes seeking out a suitable PC-mount tube socket, 6AQ5 pentode, maybe even a stash of vintage FT-243 Novice crystals hidden away for decades until you stumble

across them for sale. Or, just hit [eBay](#), [Mouser](#), and [DigiKey](#) to make short work of it! How you mount the transmitter board opens up lots of options: just a simple wooden base like a breadboard? Or house the board in a larger cabinet with a front-panel crystal socket, key jack, and cathode current meter? It’s entirely up to you—but the often-hard part for many—*laying out the circuit*—has already been done for you.

You’ll just need a power supply that can deliver 300v DC at 50 mA for a plate input power of 15 watts (about 7 or 8 watts expected output).

You can start your [AWA transmitter journey HERE](#).

-Dave **W7UUU**

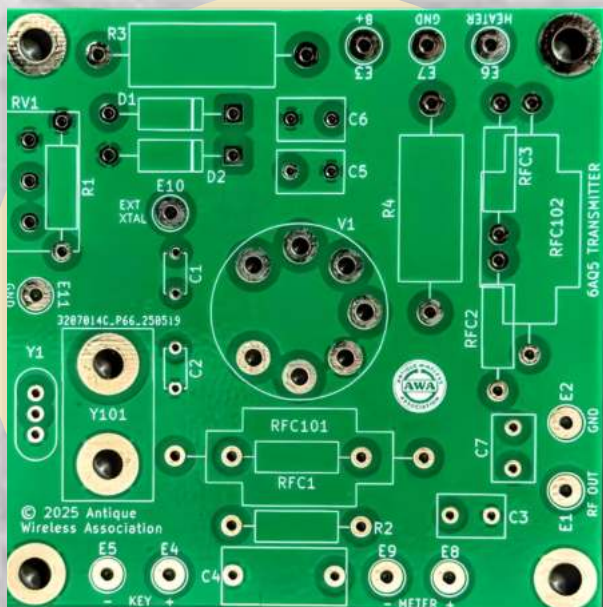

PC Board for the Antique Wireless Association 6AQ5 tube transmitter. I just received the board but have not yet begun sourcing parts. Photo by Dave **W7UUU**



Completed 6AQ5 transmitter as posted on the Antique Wireless Association page  
Photo by ©AWA 2025

# Homebrew & Kits corner

## G3EDM PEASHOOTER

### BACKPACKER TUBE RIG!



MARTIN G3EDM OF WYE, ENGLAND HAS BEEN A tube aficionado for many years and a homebrewer as well. In fact, his home station is 100% homebrew consisting of a basic but well-performing tube-based regenerative receiver and a 7-watt transmitter for 40 meters. With this setup he has worked stations all over the European Union and as far away as Florida in the United States.

He is also an avid hiker and sometime last year, he began planning a 120-mile hike along the [North Downs Way National Trail](#)—a long-distance footpath following the North Downs ridge, which is a long chalk escarpment, or slope. The path passes south of London via Dorking, Reigate, close to Maidstone, eventually reaching Martin’s home of Wye in Kent. Originally the hike was planned as just a hike.

But in April, he had the idea of building a tube-based portable transmitter—receiver and to see how many CW contacts could be made on 40-meters over the roughly 2-week journey. So that’s where the idea of Martin’s Peashooter (as he calls it) began.

The inspiration of the design was loosely based on the [September 1950 QST](#) article by Robert Vreeland, **W7YBT**, entitled, “The Mountaineer—A Hiker’s Portable”. This was a tube-based battery-powered lightweight (as far as tube rigs go) transmitter and receiver in a single portable cabinet.

To save valuable battery power, both the original design as well as Martin’s version use directly-heated “battery radio” tubes with mostly 1-volt filaments (the 3A4 RF final tube being the exception at 3v).

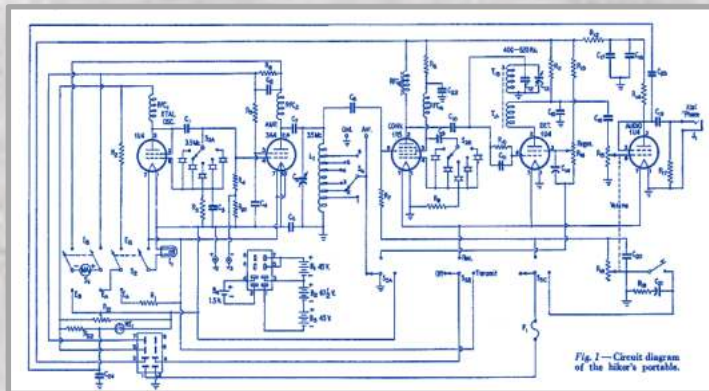

The original “Hiker’s Portable” from QST, September 1950. Martin adapted this circuit, eliminating as much unnecessary circuitry as possible to reduce the weight.

Image ©ARRL—click image to read the full QST article online

The receiver and transmitter as implemented by Martin covers only the 7.00 to 7.060 MHz segment which of course is the CW end of the 40m band. The receiver is a single-conversion superhet with a regenerative detector and single stage audio output. A 1R5 serves as the front-end and direct converter stage to a 1U4 detector and a 1U4 audio stage.

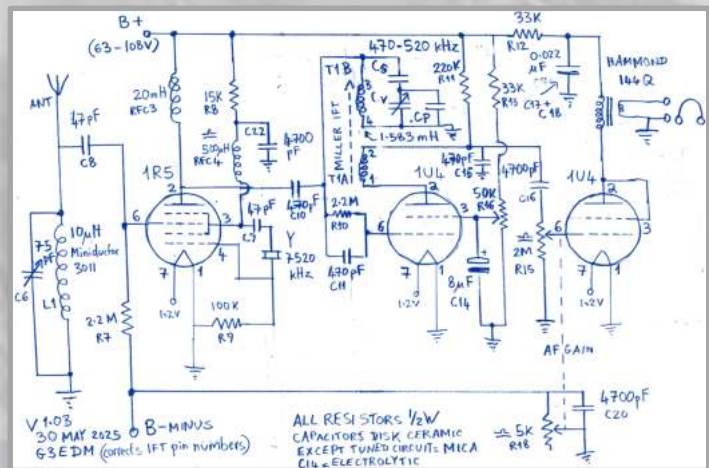

Three-tube superhet for 40-meters as built by Martin G3EDM for his Peashooter rig.

# Homebrew & Kits corner

## G3EDM PEASHOOTER BACKPACKER TUBE RIG!



The transmitter portion of the Peashooter uses a 1U4 Pierce oscillator (crystal controlled) to drive a 3A4 RF amplifier. With 130v DC on the plate, the output of the transmitter (as estimated by Martin) is around .7 watts (700 milliwatts). A 3A4 is capable of up to 2 watts of RF output, but due to size and weight limitations of the Peashooter, battery capacity had to be capped at 130v (15 rechargeable type PP3 Lithium-Ion batteries in series, that only reach about 8.7 volts each instead of 9). Martin added an NE-1 neon bulb relaxation oscillator as a CW monitor to make for easier sending.

The transmitter panel and receiver panel are completely separate, which means the Peashooter is not a transceiver but rather a transmitter and receiver in the same cabinet (similar in concept to a Heathkit HW-16 novice rig). There is a manual Transmit-Receive (TR) switch located near the key on the front panel of the rig.



Having followed a number of Martin's homebrew projects over the years, his construction skills are pretty amazing. This is especially true considering he only thought to start the Peashooter project less than two months before the 120-mile hike was to begin. Final critical construction and troubleshooting literally continued until the 11th hour, with the rig being completed only a day before launch.

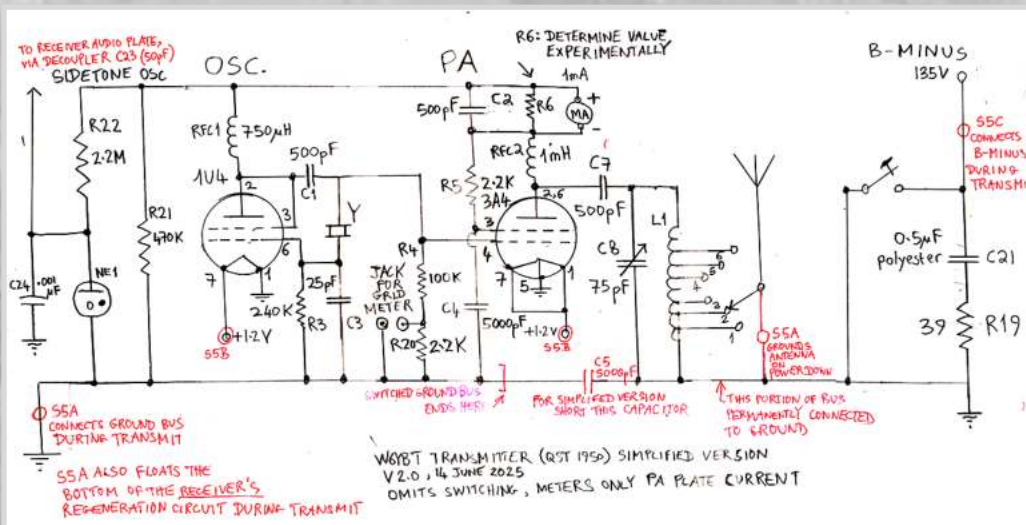

Martin's antenna was an adaptation of an EFHW that he had on hand. He sized it down and used balsa for the winders to reduce weight.

The 2-tube transmitter as adapted from the original by Martin G3EDM. The multi-tap tank coil helped greatly during his hike in dealing with varying antenna matching challenges.

# Homebrew & Kits corner

## G3EDM PEASHOOTER BACKPACKER TUBE RIG!



G3EDM/P						
2025	RST	RST				①
DATE	TIME	CALL	SENT	RCVD	FREQ	NOTES
1/7	1545	GM3ZMA		559	7036	Jim. Aberdeen.
LOWER FROYLE	2/7	G6BHB		539	7036	John. Isle of Wight
CLAYPIES WOOD	11	G4MAD		339	7036	Paddy. Warwickshire
"	1310	GØNXA		249	7036	Giles. Tewkesbury
"	1330	M5ABP		559	7036	Dave. Essex
● 3/7	1810	MØLEP		579	7036	Rick. Dursley.
COMPTON	1830	G4MAD		439	7036	See 2/7. GRM+QSB
	2040	GØGGA	-	339	?7036	Rich. Leicestershire
	2100	GØTRT		559	?7036	Cie. Nr Bath.
	2230	GØGGA			7007	See 2040G
4/7	0200	WØPV		579	7007	John. Florida.
COMPTON	0215	W9BRD		559	7007	David.
6/7	-	-	-	-	-	Indoor Ant Experiment
ALBURY	5/7	G3TXL	599	559	7036	Angus. Nr Plymouth
THE SPAIN WOOD	1530	GM3ZMA	539	229	7007	Jim. Aberdeen
● 6/7	1900	-	-	-	-	Operated. NO CONTACT.
● 7/7	1930	-	-	-	-	"
TATSFIELD	2030	-	-	-	-	"
8/7	1300	G3TXL	529	559	7029	See 5/7.
WESTERHAM HILL	1320	G4AYR	559	559	7029	Terry. Oxford
9/7	1300-	-	-	-	-	Operated. NO CONTACT
BIRCHESND	1430	-	-	-	-	"
10/7	1740	G3TXL	599	429	7036	See 5/7.
BLUEBELL HILL	1930	MØLEP	559	319	7007	See 3/7.



The 130v battery pack shown ready to drop into the slot at the top of the chassis. The rechargeable AA cells provide all filament voltages. Right: the nightly charging ritual!

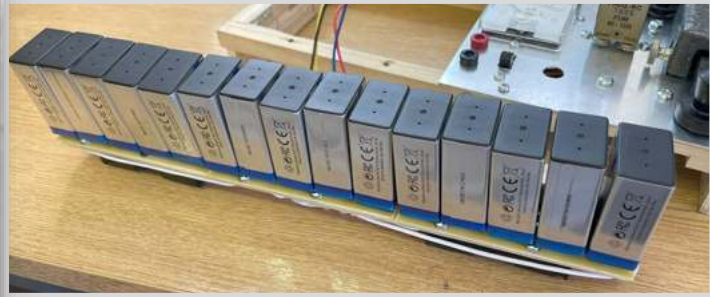

15 type PP3 Lithium-Ion "9v" (actually 8.7v) batteries in series

2025						
	RST	RST				②
DATE	TIME	CALL	SENT	RCVD	FREQ	NOTES
11/7	2110	G4HOJ	539	529	7007	Philip
THURNHAM	12/7	-	-	-	-	Operated. No contact
LENHAM	1700-1905	-	-	-	-	



The receiver tuning dial was calibrated to match the exact frequency of the 8 FT-243 crystals that Martin bought on the journey

Martin's antenna was an adaptation of an EFHW that he had on hand. He sized it down and used balsa for the winders to reduce weight.

Martin's final logbook of the journey. In total he made 17 QSOs, of which 5 were the same station, for a total of 12 unique QSOs. All of these covered England and Scotland, with the "best DX" (as refers to distance, not nation) being GM3ZMA who was about 420 miles away between Lower Froyle and Aberdeen, Scotland. Not bad for a homebrew, battery powered tube rig running 700mW into an EFHW!

# Homebrew & Kits corner

## G3EDM PEASHOOTER BACKPACKER TUBE RIG!



*A pre-launch photo of the homebrew tube Peashooter*

If you would like to read the full story of the building of this wonderful tube rig, you can find a lengthy thread [HERE](#) (requires being a registered user of QRZ.com). For a full travelogue of the hike itself, complete with all the historic sights and inns along the way, as well as many insights into the Peashooter itself, just click [HERE](#).

Many thanks to Martin **G3EDM** for sharing this amazing build and cross-country trek—truly an epic adventure!

-Dave **W7UUU**

ALL photos provided by Martin **G3EDM**



*One of Martin's many stops along the way—here seen operating on the verge of a country lane in Claypits Wood just north of the market town of Farnham*



*Some nights and early mornings were spent operating from the many inns along the way*



**THIS IS A FIRST FOR A BARK ARTICLE (OR BARTICLE** as I like to call them)... it's a review of a seemingly cool product that I do NOT want to recommend anyone buy. It is a small switching-type high-voltage (up to 420 volts DC at 30 mA) power supply that would seemingly be great for small tube projects on the bench. I picked this supply to power the TMMM tube transmitter kit found just a few pages back in this issue. It was the supply recommended by the designer of the kit featured in that piece, in fact. However I should have read the bad Amazon reviews *first* (how many times have we all said that?).

**My plan was to put it on the bench and sweep the no-load voltage** range before connecting to a load to measure actual current. However, I immediately noticed that even with the voltage control maxed out, and no load present, the maximum I could get was 229 volts—and only for a short while. Soon it began sagging until it dropped to 110. The supposed 1.25v to 12v filament supply was stuck at 13.24 volts and turning the filament voltage control made no difference. I also noted that the bleeder resistors are way too small. Sure, they do their job—*eventually*. But from 229 volts to 10 volts took a full three minutes. I guess they figure no one would run it without a load (which would bleed the caps more rapidly) but that's a poor design. It should have sufficient bleeder resistors to discharge the caps almost instantly after powering off. If you decide to buy one of these yourself, just be aware of that: it could still output potentially lethal voltage for much longer than you would expect.

**Could it be rebuilt to perform to specs? I'm sure it could.** But why take the time? I will build a linear power supply instead and do it right. So—my work is done—you have been warned *not* to buy this supply. And this time, I didn't even provide a link to the ad on Amazon!

-Dave W7UUU



The power supply board as tested on my workbench  
Photos: Dave W7UUU



High Voltage DC-DC Boost Converter 12V to 150V-420V 170W 230V & 1.25V-12V 6.3V Filament Adjustable Step Up Power Supply 2-Way PSU Regulator Module for Tube Preamp/Nixie Tube  
Brand: QINIZX  
3.0 ★★★★★ (23) | Search this page  
\$18<sup>99</sup>

*This is the photo and ad from Amazon. Seemed like a great deal—420 volts (at up to 30 mA) would provide an RF input power of 12.6 watts (or 5-6 watts output) with a small transmitter. You get what you pay for!*

# Homebrew & Kits corner

## METUBES, MEPADS, AND TUBE SOCKETS FOR BUILDERS!



AS MENTIONED IN THE TMMM SINGLE-TUBE “Tube Michigan Mighty Mite” transmitter article earlier, I just learned about these nifty homebrew soldering pads call MeTubes and MeSquares. They are sold by the small QRP shop called [QRP-me](http://QRP-me.com). One sheet of the MeTubes contains 10 tube prototyping pads for experimenting with different tube types. To use you simply snap them apart, then superglue (or hot glue) the pad to the copper side of a blank PC board. Then you solder an appropriate “PC board mount” tube socket such as seen at the right. You just have to use needle-nose pliers to bend the legs flat for soldering to the MeTube plate. For attaching other parts and linking wires, you use the little squares, called MeSquares, and glue them where needed. Think of them like single-point terminal strips. Of course, all of this you can make yourself if you have PCB etching skills. For the pads, you can simply use small cut-up squares of think PC board material.

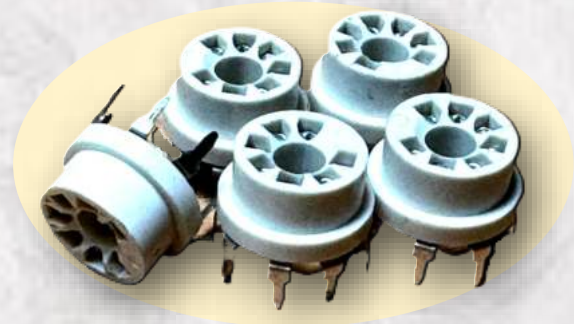

The tube sockets can be found on the websites of many vendors, but I was able to source a 5-pack on eBay for about \$2 per socket, with shipping factored in. (Not linked here due to the short life-span of eBay ads but if you search PC-mount tube sockets they are easy to find).

These are fun and inexpensive tools for anyone wanting to experiment with building tube projects of most any kind.

-Dave **W7UUU**

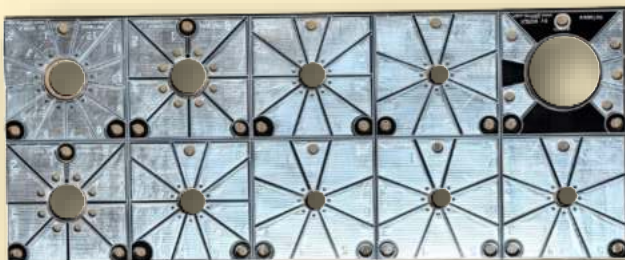

All photos by  
Dave  
**W7UUU**





# STRAY TOPICS OF INTEREST: Tube Reference Books for Hams



HERE ARE A COUPLE OF BOOKS FROM MY OWN LIBRARY that I can heartily recommend for anyone wanting to experiment with tube projects “in this modern era”.

First is the classic Ludwell Sibley “Tube Lore II” reference book. The extended 2nd edition covers thousands of tubes and includes a data CD ROM with supplementary content covering strange and rare tubes. 288 pages of detailed technical tube data for just any tube you can encounter. Click the book image or the inset image to view at Antique Electronic Supply.

Second is the wonderful “Hollow State Design 3rd Edition” by Grayson Evans, **KJ7UM**. 333 pages (8.5” x 11” pages!) packed with invaluable information about all things tube (or Thermatron, as Grayson prefers to use). Not only does the book cover theory of things like mixers, power amplifiers, and oscillators but it also offers actual build-it projects with the entire theory behind the project all laid out so readers can learn all about what they are to build. It’s very easy to read, and covers lots of practical aspects of how to design and build with Thermatrons (tubes). Very fun book. Click either image below to view on the Electric Radio website. And of course, no affiliation.

-Dave **W7UUU**





**THE JEFFERSON TUBE REJUVENATOR, INTRODUCED IN AUGUST 1925** by the Jefferson Electric Manufacturing Company of Chicago, was an innovative solution to a common and expensive problem faced by early radio owners—worn-out vacuum tubes. Tubes of the era, such as the UX-201A, UV-199, and C-299, often lost efficiency over time as their filaments became “poisoned” with oxides or other contaminants, reducing electron emission and degrading performance.

Rather than replace the costly tubes outright, owners could try to *rejuvenate* them. The Jefferson device worked by applying a brief surge of high voltage—known as a “flash”—to the filament, followed by a more controlled aging voltage via an internal transformer. This process essentially burned off the accumulated impurities from the filament’s surface, restoring electron flow and tube function for at least a while.

Housed in a compact, steel box and equipped with nickel-plated tube sockets, the rejuvenator could service two tubes at once. It plugged into standard 115-volt household current and sold for somewhere between \$7.50 and \$14.55 depending on options—less than the cost of a pair of new tubes. It was widely advertised with the promise of “keeping radio tubes like new.”

Users of the time reported mixed but generally positive results. When used *sparingly*, the rejuvenator could indeed coax a few more months of life out of a tired tube. However, overuse could cause the filament to overheat and burn out completely, especially if the user was too aggressive with the “flash” setting.

For the 1920s radio hobbyist or service tech, the Jefferson Tube Rejuvenator was a clever, economical alternative to frequent tube replacement. At least a couple of times per tube anyway.

-Dave W7UUU

## Better reception this season than last !

WOULD you like better radio reception this fall and winter than last? Better distance? Better volume? Better tone? You will enjoy better results in every way, this season, if you keep your tubes at full efficiency with the Jefferson Home Tube Rejuvenator.

All tubes deteriorate rapidly with use. The Jefferson Tube Rejuvenator “brings them back” in 10 minutes! Use it once a month—keep your tubes like new. Completely restores paralyzed or exhausted tubes. Doubles and trebles tube life, quickly paying for itself through this great saving.

Takes large or small tubes—types 201-A, 301-A, UV-199, C-299, 5-VA. Attach to any alternating current electric light socket in your home. The Jefferson Home Rejuvenator for tubes is as essential for satisfactory radio reception as a charger for storage batteries. Get one now; start the season with your tubes in perfect condition. Sold by leading dealers in radio supplies, and fully guaranteed.



for HOME Use



**JEFFERSON**  
Radio Transformers

Your radio, no matter how costly, can be no better than its transformers. Our experience as the world's largest manufacturers of small transformers is everywhere recognized by leading radio engineers who carefully specify “Jefferson.” If you want amplification without distortion—clear, pure, sweet, natural tones from your radio—make sure it is equipped with Jefferson Transformers. Sold by the better radio dealers, used by leading set manufacturers.

**\$7.50**  
\$10 in Canada

**JEFFERSON ELECTRIC MANUFACTURING CO.**  
501 So. Green St., Chicago, Ill.

Makers of Jefferson Radio, Bell Ringing and Toy Transformers; Jefferson Spark Coils for Automobile, Stationary and Marine Engines; Jefferson Oil Burner Ignition Coils and Transformers.



**JEFFERSON**  
**TUBE REJUVENATOR**  
Keeps radio tubes like new



## Plan Now: Upcoming POTA!

By BJ KO7T

### RADIO CLUB OF TACOMA POTA 2025 Schedule

This past year, the club hosted 11 POTA activations at 7 different parks, and we have BIG plans for 2025!

The Club's POTA Chairman, BJ KO7T, is always looking ahead for fun new parks in the state to activate. It's always a great way for members to get involved with amateur radio while enjoying the great outdoors here in Washington State!

Here's the upcoming schedule:

**PARK:** Mount Walker - Olympic National Forest (US-3542)

**DATE:** August 10th

**TIMES:** Meet at club at 8:00

**NOTES:** It is approximately a 2-hour drive from the club to Mount Walker which is south of Quilcene. We will carpool and caravan from the club up to the mountain. There is a road to the top, **but there are no facilities**. This will be a fun adventure!

**PARK:** Manchester State Park (US-3227)

**DATE:** Sept. 14th

**TIMES:** 10:00 AM PST

**NOTES:**

**Everyone is invited to come** to our POTA activation events. It's a great opportunity to learn about different antenna types, setting up and tuning antennas with loading coils and/or a counterpoise, learn about different digital modes, and other topics related to portable operations. We usually have 3 to 5 stations set up running many modes on multiple bands. We encourage prospective hams to get on the air, and those with Technician licenses to operate on different bands with a control operator. For club members with a General license, we even have a portable POTA kit that is available to check out from the club the Saturday prior to our club activations. Please see or [email BJ Rollison \(KO7T\)](mailto:BJ KO7T) for more information.

-BJ KO7T



BJ KO7T operating at a recent POTA activation



## Parks & Summits on the Air Activities

### ONE ASPECT OF THE PARKS ON THE AIR (POTA)

program that I like the most is that it encourages me to seek out and explore places to operate a portable station that I might otherwise not visit in my travels, both domestically and internationally. Whether I am solo traveling for adventure or with my family on vacation, I always carve out some “me time” to explore the amazing parks and natural areas that are preserved for the public to enjoy.

Last month I flew down to Texas to visit family and play radio in Texas parks! I activated a few parks relatively close to my mother’s house last year, but this year I wanted to venture a bit further. I did not grow up in Texas, but I’ve learned that “down the road” means anything within a 20-mile radius, and “relatively close” is pretty much anything within a 4-hour drive. So, in the week prior to my departure, I scoped out the parks on the POTA map, packed my radio kit, and was ready to play POTA in Texas!

**My first activation was at the Barrington Plantation State Historic Site (US-6538)**, which is within the



Barrington Plantation US-6538 Photo by BJ K07T

**Washington on the Brazos State Historic Site (US-3512)**, just down the road from my mother’s home.

This is known as the birthplace of Texas and is the site where delegates formally announced separation from Mexico on March 1, 1836. The Barrington Plantation is a “living-history” site, and the buildings are immaculately preserved—well worth the visit to get a glimpse of life more than 150 years ago. They don’t allow operations within the plantation grounds, but there are places to set up and operate near the entrance or in the parking lot. This is by far one of my favorite parks in eastern Texas (so far). Lots of history and beautiful scenery.

**Next, I decided to venture to Galveston Island State Park (US-3013)**, a short 88 miles away. The incredible highway system and 75 MPH speed limits made the 1.5-hour drive feel “relatively close.” This 2,000-acre park has two separate sections: the Gulf of Mexico side and the West Bay side. The gulf side has a nice beach and several large pavilions, but it tends to be quite windy, so I drove over to the bay



Galveston Island US-3013 Photo by BJ K07T



Galveston Island US-3013 Photo by BJ K07T

side to scout operating locations away from the beach. I found a spot with four covered picnic tables that provided some shade and a great location to set up. Although this location is popular with folks coming to fish and with kayakers, there was ample room to set up my [Buddistick Pro antenna](#) with a single vertical pointing due north. Despite the high temperatures, the shade and the constant breeze made operating here comfortable, and I enjoyed watching young kids' excitement as they caught potentiometer fish

**I've operated from more DX locations than U.S. states,** so one of my planned POTA activations on this trip was to drive across state lines to activate the Sabine Island Wildlife Refuge in Louisiana (and also grab some delicious Cajun seafood gumbo). This is a huge 125,000-acre area of marshlands, lakes, and canals that is apparently only accessible by one road passing through the eastern side of the refuge. When I

entered "Sabine National Wildlife Refuge" into Google Maps, it couldn't provide a route. So, I got directions to Hackberry, Louisiana, and set out on my adventure. Just shy of three hours later, I arrived in Hackberry. Eight miles south of town, Highway 27 appears to be the road that provides access to the refuge for about nine miles. There are a few turnouts along the road with parking but no shade. I finally opted to stop at the Blue Goose Trail parking area. A visitor center appears to be under construction, but there was still no shade to be found, so I operated from the back seat of the rented minivan with all the doors open to keep things at a somewhat reasonable temperature. After logging about 70 contacts, I packed things up and walked down the half-mile trail. It was a nice flat walk on a paved surface, and no alligators were sighted. I found a place for a late lunch and headed back to Texas.

**Back in Texas, the next park on the docket** was [Somerville Lake State Park \(US-3030\)](#). This park has two



Sommerville Lake operation position Photo by BJ K07T



separate units connected by a 13-mile trail: the Birch Creek Unit and the Nails Creek Unit. I opted for the Nails Creek Unit on the southwestern side of the lake near the boat ramp. Having the luxury of visiting parks during weekdays means fewer people and lots of choices for where to set up. I was told that this park also includes the [El Camino Real de Tierra Adentro National Historic Trail \(US-4569\)](#). However, a few minutes of research showed that the trail system only crosses through Rocky Creek Park (which is not a state park). Trail systems are often hard to identify, but National Historic Trail Association and National Park Service maps are extremely useful.

**My last park to visit on this trip was Brazos Bend State Park (US-2992).** This park covers almost 5,000 acres and includes several lakes and lots of marshlands where the alligators like to roam, precluding park-goers from swimming in those lakes—for good reason. I chose to set up near the Elm Lake area of the



Brazos Bend State Park Photo by BJ K07T

park. There were a lot of trees for shade, and picnic tables were plentiful. There are some nice trails to walk, and the observation deck at Elm Lake was a good place to spot some interesting birds. There were no alligator sightings, but the squirrels were very curious, and one even hopped onto the picnic table. The park is really picturesque, but I would recommend wearing long pants and taking along mosquito repellent.

**It was a great trip.** I got to see more of the states, visit some of our beautiful state and national parks, and take in some amazing scenery. June is not necessarily the best time of year in the Southeast. It's the beginning of hurricane season in that part of the world, and thunderstorms are an almost daily occurrence. There's a lot of static in the air, which can affect transmissions. Once the storms pass, the humidity can get uncomfortably high. It's important to drink plenty of water and take care of your equipment. On the plus side, the land is flat. Not pancake flat—it's flatter than pancake flat—which is really good for getting a signal out, especially compared to the Pacific Northwest, where I sit between two high mountain ranges to the east and west of me and occasionally have to battle the aurora trying to get over the pole to EU-land. Despite the challenges of playing radio in various locations, at the end of the day it's not the number of contacts that I remember. It's the natural beauty of the places I visit that provides the lasting memories I will always cherish.

-BJ K07T

# STRAY TOPICS OF INTEREST

Fun stuff for Hams to read!



W7UUU

## Hidden Word Contest

This month's hidden word and object is **potentiometer**. This critical electronic part was invented by [Johann Poggendorff](#) in the 1840s. It's simply a variable resistor used to control voltage in a circuit. Originally developed for measuring electric potential, it evolved into a key component for adjusting audio levels, voltages, light levels, and many other applications. A typical potentiometer consists of a resistive track and a wiper that slides across it, varying resistance and thus changing the output. Even in this era of digital everything, a majority of ham gear often contains many potentiometers. Today, both rotary and linear types are found in analog electronics and user interfaces, though digital versions *are* increasingly replacing them in modern gear.

-Dave **W7UUU**

## Hidden Object Contest

This object will be hidden on a page in the bark. Find it, tell me which page, and WIN stickers from W7DK as well as QRZ.com  
This page of course doesn't count!



## Famous Ham August Birthdays

Arthur Godfrey—born August 31, 1903, was a very popular American radio and television broadcaster from the 1940s through the 1960s. Known for his relaxed, folksy style, he hosted programs like Arthur Godfrey Time and Talent Scouts. He was a skilled pitchman and ukulele player, and also held a pilot's license. But for our purposes, he was a very active amateur radio operator with the call sign **K4LIB** and appeared in the logs of hams world wide.

-Dave **W7UUU**



Arthur Godfrey**K4LIB**(SK)—photo: Wikipedia

# STRAY TOPICS OF INTEREST

## Survey Center & QSL of the Month



W7UUU

### Survey Center!

A SURVEY WAS POSTED RECENTLY ON QRZ.COM ASKING AN INTERESTING QUESTION: "Should we move away from using OM/XYL/YL terms in ham radio?" It was a somewhat short-lived survey, about two weeks—but it drew a surprising number of responses: 128 in all. The ham who posed the question, in his initial post, clearly feels that hams should not be using such terms today. He refers to them as "definitely outdated and brash". But the results were a resounding rebuke of that sentiment—with 111 (86.7%) voting "NO" and only 17 votes (13.3%) agreeing with the premise. The very first reply to the survey, by Eric **KL7AJ**, more or less summed up the tone of virtually the entire discussion in this way: "No because we have a lot of old men, young ladies, and ex-young ladies. Pretty simple. And besides, I'm outdated and brash"

So what do you think? Should hams retire these terms? Shoot me an email and let me know.

-Dave **W7UUU**

### Tube-Themed QSL Cards of the Month

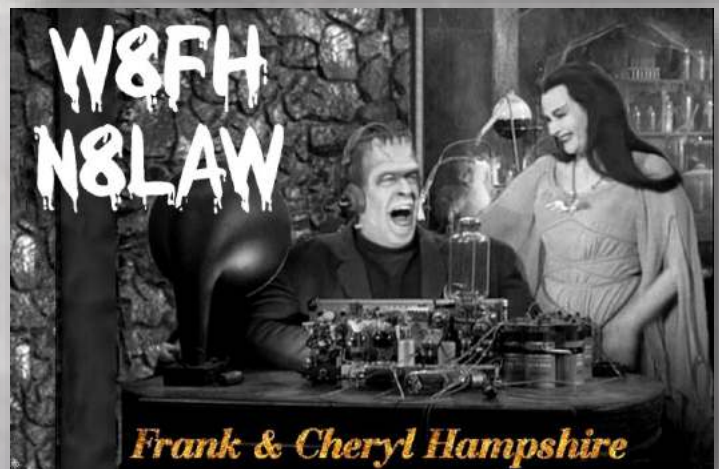
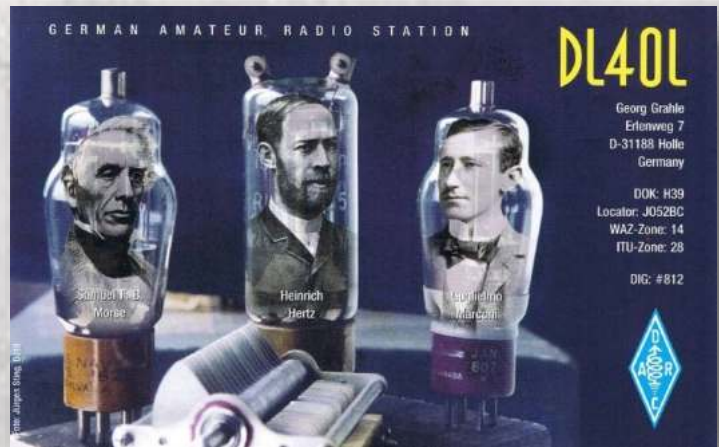

? Should we move away from using OM/XYL/YL terms in Ham Radio? - If not, why not? Leave a comment!

Edit

Poll closed Jun 13, 2025.

Yes	<div style="width: 13.3%;"></div>	17 vote(s)	13.3%
* No	<div style="width: 86.7%;"></div>	111 vote(s)	86.7%



From the shack of Rich **KR7W**: "HR1680 receiver and HX1681 transmitter both have been refurbished using guidance from 6 excellent "How To" articles written by Steve **KW4H** that appeared in [The Spectrum Monitor Magazine, Dec 2024 to June 2025](#). The High Frequency Oscillator (HFO) circuit boards in both radios have been souped up with [ProgRock2 frequency generating modules](#) that replaced most of the components along with the aging and drifting quartz crystals. Also in the HR1680 receiver- the power supply and crystal calibrator were replaced with modern circuitry.

The ProgRock2 modules and other items were purchased from Steve **KW4H**'s ad listed at [QRZ.com- Ham Made Gear For Sale section](#). I also replaced the aging and slipping vernier dials with brand new Jackson verniers for much more stable tuning performance.

Refurbishing these rare and unique Heathkits was fun, mindful, but sometimes arduous.

The HR1680 receiver has improved in sensitivity to the point where the RF Gain control needs to be turned down. The transmitter power output is 110+ watts 80M to 15M, 75 watts on 10M. Sharp eyes will notice the SB-600 speaker—which is used to house the required HP-23B power supply for the transmitter (**which uses a 12BY7 driver tube and a pair of 6146B final tubes**).” -Rich **KR7W**



# W70S DOC SPIKE MUSEUM

## Featured Gear from the Museum

Photos & Text by Dave W7UUU



and no current will flow. That's how a diode tube works. Of course, a regular lightbulb would not perform well. It requires a more specialized filament and a stronger vacuum inside the glass than a light bulb has. But you get the general idea.

**So why would the early spark transmitters need to run off batteries instead of AC mains power?** There are a number of good reasons. Batteries produce a pure stable DC current with zero "ripple" content such as an early AC-powered supply would generate. That means the spark signal would have much less "buzzsaw" sound to it when received. Another reason was isolation from the 115v AC mains for safety... one less point of danger in the already pretty scary machine that is a spark transmitter. Lastly, portability. Due to the often-intense noise and mess that a spark rig produced, early hams very often literally used their shack in the backyard for radio (which is where the term radio shack derives). But such shacks seldom had the luxury of mains power so batteries were the only option.

**This really is a wonderful piece of radio history**—it offers a tangible connection to what hams were doing around 1916, when the Radio Club of Tacoma was founded. While there is no record of the original owner (not that I found anyway), it's pretty safe to assume it belonged to a very early member of W7DK, if not one of the founders himself. I hope you enjoyed this little slice of "real radio history" - I certainly had a great time researching this.

-Dave W7UUU



Note the Fahnestock clip used for the anode connection



The glass nipple on the side suggests the glass bulb was hand blown. Research confirms this.

All photos by Dave W7UUU

# ANTENNA TIME

## Magnetic Loop Antenna (STL)

Dave W7UUU



**ONE OF THE MORE POPULAR ANTENNA CHOICES** for those living in an HOA or similar “stealth antenna” situation is the Magnetic Loop or as it’s sometimes called, an STL or Small Transmitting Loop antenna.

**At first glance**, a small transmitting loop antenna seems like it couldn’t possibly work. It’s physically tiny—often just three to six feet in diameter—and it lacks the elevated structure and long wires we usually associate with serious HF operation. But it’s a surprisingly effective option for hams with limited space, as long as you understand the principles behind its operation.

**A small loop is fundamentally a high-Q tuned circuit:** a continuous loop of conductor, usually copper (most often in the form of coaxial cable) or aluminum tubing, with a variable capacitor bridging the ends. The loop acts as an inductor, and the capacitor working with that inductor forms a resonant LC circuit tuned to the desired frequency. When resonance is achieved, the circulating current in the loop becomes extremely high—from a few amps to as high as 20 amps—with just 100 watts of

input power. That high current generates a strong magnetic field around the loop, which in turn radiates RF energy into space.

**The “small” in small loop refers to** the fact that its circumference is less than one-tenth of a wavelength.

This compact size leads to a characteristic radiation pattern—broadside to the plane of the loop, with deep nulls off the ends. But the tradeoff is very narrow bandwidth. Even a minor frequency change can detune the system, requiring constant adjustment, especially on SSB.



WIMO Magnetic Loop Antenna  
“Baby” model covers 40-10 meters  
250 Watts maximum power  
Click photo to visit their site  
Photo © WIMO.com

**One feature often seen on small transmitting loops** is a secondary, smaller loop positioned near the bottom, top, or at the side of the main loop—sometimes called a

Faraday Loop. This smaller loop isn’t part of the resonant circuit—it’s a *coupling* loop. Instead of a direct wire connection, the transmitter feeds this secondary loop, which *magnetically* couples energy into the main loop. This inductive coupling allows for a balanced feed and simplifies matching without needing a tuner or balun. By adjusting the size and

# ANTENNA TIME

## Magnetic Loop Antenna (STL)

Dave W7UUU



position of the coupling loop, you can fine-tune the transfer of power for efficient operation.

**Efficiency is a constant challenge.** On the higher HF bands—say, 20 or 17 meters—a well-built loop with a quality vacuum variable capacitor and smooth joints can deliver excellent results. But on 40 meters and below, resistive losses eat away at performance unless every component is carefully optimized. High circulating voltages, sometimes thousands of volts, also demand generous spacing and robust insulation.

*Which brings up an important disclaimer: under the right circumstances, the potential for severe RF burns, electrical shock, and in the most extreme cases involving high RF feed power from the radio, **lethal** potentials can exist. Make sure you fully understand the safety concerns of using STL antennas. Even power as low as 20 watts can cause voltages across the capacitor sufficient to cause injury.*

**Perhaps the most unexpected benefit** of the small loop is how quiet it is on receive. Because it responds primarily to the magnetic component of RF, it naturally rejects much of the electric-field noise common in urban settings—making it a favorite among apartment-dwelling or HOA-limited hams.

**Not all STL antennas are created equal.** The lower end units (as low as \$200) will always be rated for very low power levels due to the cost of high-power variable capacitors. They will also always be manually adjusted, and seldom with a vernier dial to slow the tuning.

It can be very frustrating to tune such an STL every time you change frequency. That's fine for FT8 which is "set and forget" - but for SSB or CW when you're moving around the band it can be a pain in the neck.

The next tier up in STL antennas offer larger variable capacitors and use smooth vernier or remote fine tuning controls. But above that level, you get into the high end systems that use complex autotuning mechanisms (Stepper motors and other methods). This is where extreme convenience and higher power levels become possible—but the price tag will reflect that... often priced well into the thousands of dollars.

**STL Magnet loop antennas won't often** (ever?) outperform a full-size beam on a tower, but still they can get hams on the air who might otherwise not have any chance due to their living circumstances.

When space is tight, noise is high, or portability is essential, this clever design offers a practical and elegant solution—all from a humble ring of tubing, a carefully chosen capacitor, and a little ingenuity.

-Dave W7UUU



Alpha Antenna  
100w HF Loop  
[Click logo to visit site](#)

# COOL GEAR!



## Interesting Bits of Gear Any Ham Can Use

By W7UUU

### I'VE LONG BEEN A SUCKER FOR COOL LITTLE

component testers that can automatically test and read values of electronic parts. But the one featured in this Cool Gear column is by far one of the most comprehensive I've found, and has a selling price on [Amazon for under \\$30](#). It's called the FNIRSI LCR-P1 and it tests just about any component you could possibly need to test:

1. NPN & PNP bipolar junction transistors
2. N-Channel and P-Channel MOSFETS
3. JFETS (Junction Field Effect Transistors)
4. IGBTs (Insulated Gate Bipolar Transistors)
5. Standard diodes of all types
6. Zener diodes
7. Light emitting diodes (LEDs)
8. Resistors of all types
9. SMD resistors and capacitors
10. Electrolytic capacitors
11. Ceramic and other fixed capacitors
12. Coils and chokes of most types
13. Thyristors (Silicon Controlled Rectifiers)
14. ESR measurements for capacitors
15. Battery testing for certain types
16. Auto-pin ID for transistors of most types
17. Parameter measurement of transistors
18. Auto-ID of most components tested
19. Infrared decoding & address ID

That's a pretty comprehensive list of testing functionality for such an inexpensive tester. Certainly there are other such testers with similar capabilities



Displaying the test of a mylar disc capacitor

Photos by Dave W7UUU



In the IR Decoding mode it will decode IR streams from devices like TV remote controls

# COOL GEAR!

## Interesting Bits of Gear Any Ham Can Use



By W7UUU

but what I feel sets this one apart is the color screen, the IR decoding (for those who need that, such as Arduino and Raspberry Pi experimenters), and the low cost.

The batteries are internal and rechargeable via a USB-C port and the charge lasts a very long time. The meter comes with a handy set of 3 external micro-clip test probes for testing parts that either won't fit the built-in socket or must be tested "in circuit". The other accessory, seen in the extreme lower right on this page, is a snap-in replacement for the testing socket. The idea is you gently remove the socket and replace it with the PC board unit. You can then solder parts onto the copper pads. I honestly think this is pretty hokey and not something very practical in the real world. The idea is you can solder SMD parts onto the pads for testing—and I suppose that would work well enough... for a few times anyway. I picture the pads becoming hard to keep free of globs of excess solder over time. But maybe there are those who would find this feature useful.

I have a fair number of similar devices to this—including a [Peak Atlas LCR40](#) which costs \$149 and doesn't deliver anywhere near what this little unit does. For all of the parts that can be tested on both (capacitors, resistors, diodes, inductors, etc.) I found that the two meters deliver essentially identical results. The FNIRSI LCR-P1 priced below \$30 on Amazon simply does a LOT more for a fraction of the cost of the Peak Atlas. It's just that simple.

This is really a great little tester for \$28!

-Dave W7UUU



Displaying the test of an NPN transistor. It reads type of transistor, the current gain, the emitter current and the base-emitter voltage

Photos by Dave W7UUU

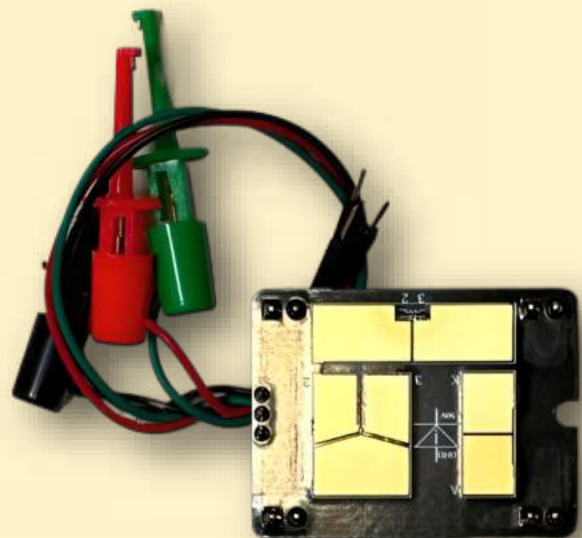

The meter comes with convenient test probes for testing parts in-circuit or on the bench. Also included is the swappable panel that replaces the locking socket panel. The practicality to me is suspect.

# STRAY TOPICS OF INTEREST:

## Top Ten & Hamfests



Dave W7UUU

# 10

### 10 Most Popular Tubes for Hams in 2025

### Upcoming Ham Fests in the Area

Data published with permission from [Lynn at N7CFO.com](http://Lynn at N7CFO.com)

For this month's Tube theme, I did some research to find the top 10 most used tubes for 2025. My search was based on searching QRZ forums, HRO and DXE comments, eHam posts and reviews, etc. It's not a scientific listing by any means but seems to be pretty much what I might have guessed.—Dave W7UUU

**August 9.** 2025, 0800 - 1300 hrs. ARRL Idaho State Convention sponsored by the Kootenai Amateur Radio Society. *This is an ARRL Sanctioned Event.* River of Life Friends Church 3263 E. 12th Ave. Post Falls, ID. Contact: Cliff Pratt, K7CVP. (208)620-8589. [k7cvp.id@gmail.com](mailto:k7cvp.id@gmail.com)

**August 15-18.** Pacific Northwest DX Convention, Clackamas, OR. *This is an ARRL Sanctioned Event.* <https://pnwdxconvention.com/>

**August 17.** Puget Sound Antique Radio Association Annual Swapmeet. <http://psararadio.com/>

**September 6.** Star/GMRS Swapmeet. Star Riverwalk Park, 979 S. Main St. Star ID. <https://docs.google.com/forms/d/e/1FAIpQLSfGKLuWh8T9Y6FpXiDPgX6lZHRFlzzH64WuVyVXGXWD6AFgQg/viewform?pli=1>

**September 8-12** 2025 GNU Radio Conference. Everett, WA. <https://www.gnuradio.org/>.

1	6146 Finals for hybrids
2	807 RF power stages
3	572B Linear amps
4	3-500Z Linear amps
5	4CX250B VHF UHF amps
6	6L6 RF amp & audio
7	EL34 for AM modulators
8	829B/3E29 VHF UHF amps
9	6SN7 dual triode
10	6C4 small RF triode



Radio Club of Tacoma Ham Fair 1970

# HAM TECH 101

By Dave W7UUU

## Useful tech info for newer hams and old

### Vacuum Tubes 101

#### VACUUM TUBES 101 – WHAT MAKES THEM TICK?

This month is “The Tube Issue” for *The Logger’s Bark*, and I thought it would be fitting to have a (very) basic overview of vacuum tubes for the younger members of the Radio Club of Tacoma. It’s very easy for some of us old timers to assume “every ham surely knows all about the tube era in ham radio” when in fact, there are a great many hams who have never even seen a tube much less worked with ham gear based on tube technology.

For many new hams, vacuum tubes probably feel like an arcane relic of a forgotten era—something out of an old sci-fi flick or a dusty shelf in a broadcast museum. And of course outside of just a handful of power amplifiers still made using tubes, there really isn’t any tube gear made anymore for hams. (We’re not talking about the “Audiophile” world where tubes still reign supreme).

But if you’re restoring classic gear or just trying to understand why your S38 you found at an antique mall glows warm in the corner, it’s worth taking a moment to understand what makes these things work.

It all starts with a simple concept called thermionic emission. When you heat certain metals—usually a coated cathode (a piece of metal inside the tube, usually closely surrounding the hot glowing filament)—they give off electrons. This is the starting point for everything a vacuum tube does.

Inside the tube’s sealed glass envelope (yes, it’s actually a vacuum in there—all (well, *most of*) the air is sucked out at manufacture—hence the name vacuum tube), a heater (the part many call a filament, that makes the tube light up) warms the cathode until electrons are released.

Now, if you place a second element—a metal plate or anode—near that cathode and make it more positive, those free electrons on the cathode will jump across the

vacuum toward the plate. This forms a flow of current, but only in one direction. Electrons can’t jump “backward” toward a negative plate, which means this simple arrangement—called a diode—acts as a one-way valve for current. It’s the most basic type of tube there is, and was extremely common and important in the era of tube electronics.

That makes the diode useful for turning AC into DC, and

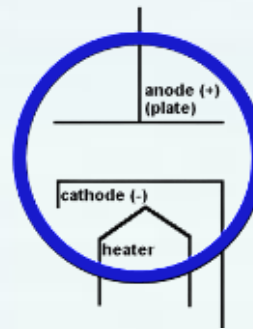

*Schematic of the simplest of tubes: the diode*

it’s why you’ll find rectifier tubes like the 5U4 and 5Y3 in vintage power supplies, receivers, transmitters—just about any ham gear you can think of. They’re just vacuum diodes handling the job of flipping alternating current into something the rest of the circuit can use.

To get from there to *amplification or oscillation*, we need a way to *control* that flow of electrons. The next step up is the triode. It works the same way as the diode, but with one key addition: a wire mesh called the control grid, suspended in between the cathode and the plate. By applying a small negative voltage to this “control grid”,

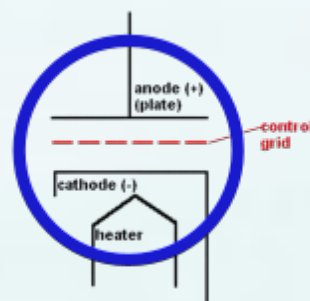

*Schematic of a triode tube where things get more interesting*

# HAM TECH 101

## Useful tech info for newer hams and old

### Vacuum Tubes 101

By Dave W7UUU

you can repel electrons from the cathode and limit or even cut off the current flowing to the plate. A very small change in grid voltage causes a much larger change in plate current, and with the right supporting circuitry, you have—*amplification*. If you feed a weak signal into the grid such as audio, at the plate it becomes a significantly stronger signal.

Tubes like the 12AX7 and 6SL7 are classic triodes used for audio stages, sidetone oscillators, and many other applications. That tiny signal at the grid gets turned into a much larger one at the plate, and as simple as it sounds, that's really the magic of tubes.

Triodes are simple and elegant, but at higher frequencies or voltages they run into problems. One of those is called secondary emission, where electrons hit the plate hard enough to knock other electrons loose—and those stray electrons can actually flow back toward the grid, throwing off your signal and making things unpredictable. Engineers fixed this by adding another grid—called a screen grid—between the control grid and the plate. This creat-

ed the tetrode (since the tube now has 4 elements). The screen grid is held at a steady positive voltage and acts like an electrostatic shield, reducing the capacitive feedback from plate to grid and helping maintain stability at higher frequencies.

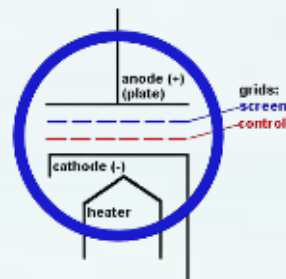

*Tetrodes can do more work but not without introducing their own issues*

The tetrode helped a lot, but it wasn't perfect either. Those secondary electrons we talked about could still head toward the positively charged screen grid, rather than returning to the plate. That created humps and dips in the output curve, known as the "tetrode kink" (see the plate-curve graphic image). So once again, a fix was added—another metal mesh called a suppressor grid, placed between the screen grid and the plate, usually connected internally to the cathode. This suppressor repels those wandering electrons and steers them back where they belong, giving us the pentode. With five internal elements, the pentode delivers stable gain, reduced distortion, and smooth amplification. Tubes like the EL84, 6BQ5, and 6AU6 are all pentodes you'll still find in receiver audio stages, IF amplifiers, and modulator circuits.

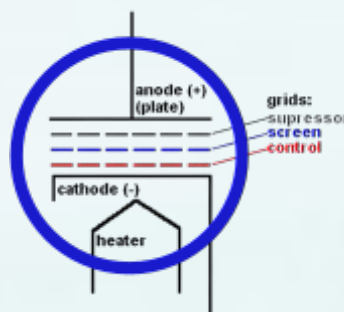

*Schematic of the pentode... one of the most versatile configurations*

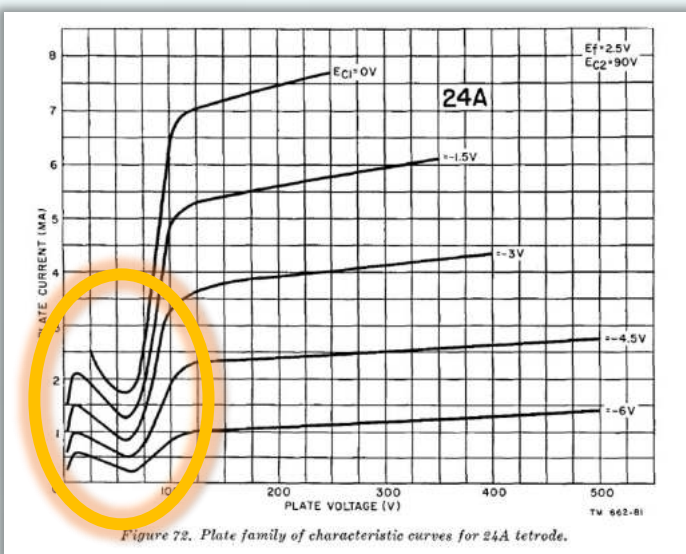

Figure 72. Plate family of characteristic curves for 24A tetrode.

Graph illustrating the "Tetrode Kink"

Image: Wikipedia

# HAM TECH 101

By Dave W7UUU

## Useful tech info for newer hams and old

### Vacuum Tubes 101

Some variations go even further. Beam power tetrodes like the 6L6 and 6146 use beam-forming plates instead of a suppressor grid to focus the electron stream into tight columns. This helps reduce screen current and boosts efficiency, making them perfect for final RF stages and power amplifiers.

There are all kinds of oddball tubes beyond these basics—Nuvistors, compactrons, dual-control pentodes, ceramic-metal transmitter tubes, and all sorts of specialized tubes seldom seen in the hobby world—but for most hams starting out, the big five are enough to know: the diode, triode, tetrode, pentode, and beam tetrode. Once you understand how electrons boil off a heated cathode, get steered and accelerated through grids, and land at the plate to create useful current, you've got the core of how vacuum tubes really work. From there, the subtleties of tubes kick in—the vast variations from one pentode to another, frequency limits, inter-element capacitance, and dozens of other factors that engineers must work out if a circuit is to perform as expected. But with just a basic knowledge of tube technology, even new hams can get their feet wet—there are literally millions of existing tube circuits from which to build, and given the billions of tubes made over the last 100 years, they are still plenty available.

-Dave W7UUU

#### SIDEBAR: Schematics vs. Reality in Tubes

When I was a 13-year-old brand new ham, for the first time seeing schematics showing tube projects I might be able to build myself, I thought I understood how a tube was constructed, based solely on what I saw in the project books... after all, it's pretty obvious isn't it? The heater and cathode are on the bottom, there's a flat little metal anode at the top (a "plate"

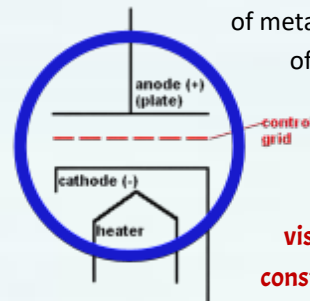

of metal), and in between was a piece of what I pictured to be a little piece of window screen—the control grid.

**I'm sure I wasn't alone in this visualization of how a tube was constructed.** But when I first started

dissecting real tubes with broken glass, I quickly realized my simplistic view wasn't even close to the reality. How tubes are actually made is *nothing* like that. In fact, much of the innards of a tube are "tubular"! The heater is a spiral heating filament in the center of the tube. Surrounding that is another close-fitting metal tube that forms the cathode. Then arranged in one of many possible ways, another tube of mesh that is the control grid (followed by more tubes of wire mesh called the screen grid and suppressor grid). Finally the Plate (anode) is yet another tube of solid metal that surrounds the whole thing. If you ever come across an old tube that's known to be defective, carefully break open the glass (wearing gloves and eye protection) and carefully "peel the onion" and you can really see just how a tube goes together. And you'll find it's nothing like the schematic symbols seen in the old ARRL books and magazines. It may even surprise you!

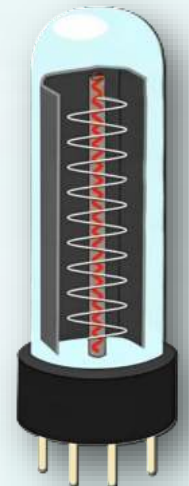

-Dave W7UUU

# FUN AND GAMES!

Crosswords, Word Search, etc.

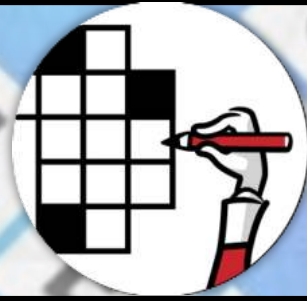

**Word Scramble Challenge! Print this page to play!**

## FAMOUS BRANDS OF TUBE GEAR!

- 1. ALNNIOAT \_\_\_\_\_
- 2. ASNW \_\_\_\_\_
- 3. OCLLSNI \_\_\_\_\_
- 4. FETLAYTEA \_\_\_\_\_
- 5. LIHAASFTCRERL \_\_\_\_\_
- 6. UALNMMHRAD \_\_\_\_\_
- 7. CIEO \_\_\_\_\_
- 8. NNJOOHS \_\_\_\_\_
- 9. TGIH NK \_\_\_\_\_
- 10. AKRDE \_\_\_\_\_
- 11. OSEGOL \_\_\_\_\_
- 12. TTAHKHIE \_\_\_\_\_
- 13. EOYSLM \_\_\_\_\_
- 14. OCMEA \_\_\_\_\_
- 15. OETMP \_\_\_\_\_
- 16. GECLG \_\_\_\_\_
- 17. DCOEIL \_\_\_\_\_
- 18. MCLEA \_\_\_\_\_

# FUN AND GAMES!

Crosswords, Word Search, etc.

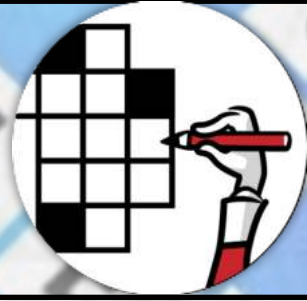

**Answer Key... but don't cheat!**

## FAMOUS BRANDS OF TUBE GEAR!

1. ALNNIOAT \_\_\_\_\_ National \_\_\_\_\_
2. ASNW \_\_\_\_\_ Swan \_\_\_\_\_
3. OCLLSNI \_\_\_\_\_ Collins \_\_\_\_\_
4. FETLAYTEA \_\_\_\_\_ Lafayette \_\_\_\_\_
5. LIHAASFTCRERL \_\_\_\_\_ Hallicrafters \_\_\_\_\_
6. UALNMMHRAD \_\_\_\_\_ Hammarlund \_\_\_\_\_
7. CIEO \_\_\_\_\_ Eico \_\_\_\_\_
8. NNJOOHS \_\_\_\_\_ Johnson \_\_\_\_\_
9. TGIHNK \_\_\_\_\_ Knight \_\_\_\_\_
10. AKRDE \_\_\_\_\_ Drake \_\_\_\_\_
11. OSEGOL \_\_\_\_\_ Geloso \_\_\_\_\_
12. TTAHKHIE \_\_\_\_\_ Heathkit \_\_\_\_\_
13. EOYSLM \_\_\_\_\_ Mosley \_\_\_\_\_
14. OCMEA \_\_\_\_\_ Ameco \_\_\_\_\_
15. OETMP \_\_\_\_\_ Tempo \_\_\_\_\_
16. GECLG \_\_\_\_\_ Clegg \_\_\_\_\_
17. DCOEIL \_\_\_\_\_ Eldico \_\_\_\_\_
18. MCLEA \_\_\_\_\_ Elmac \_\_\_\_\_

# CLOSING REMARKS

**JOIN NOW!**



W7DK

## ABOUT THIS PUBLICATION

The Logger's Bark is the official publication of the Radio Club of Tacoma and is published by RCT, PO Box 11188, Tacoma, WA 98411. The Radio Club of Tacoma is a non-profit corporation as defined by law. All proceeds will be used exclusively for charitable and educational purposes. The Radio Club of Tacoma's Club House is located at 1249 Washington St, Tacoma, WA 98405, phone: 253-759-2040.

## EMAILING OFFICERS

To contact any club officer, simply send an email to their call sign @W7DK.org

## CONTRIBUTIONS OF ARTICLES & PHOTOS

We WELCOME contributions of articles, guest editorials, blurbs, Hints-and-Kinks, shack photos, QSL cards, memorable contacts, anything of interest to your fellow members. Submit your materials via email to: [loggersbark@gmail.com](mailto:loggersbark@gmail.com) or via US mail to PO Box 11188, Tacoma, WA 98411 Nichrome

## RADIO CLUB OF TACOMA REPEATERS

Central Tacoma 2m: 147.28 + PL Tone 103.5  
 Central Tacoma 70cm: 440.625 + PL Tone 103.5  
 Crawford Mountain: 147.380 + PL Tone 103.5  
 North Tacoma: 145.21 - PL Tone 141.3

The Loggers Bark *does not* accept AI / ChatGPT submissions

## MEMBERSHIP INFORMATION

- Full-time students, licensed or non licensed, up to age 25 are \$20 per year.
- Fees are applicable for the calendar year: January to December
- Lifetime membership is 20 times the yearly fee you are eligible for. Lifetime memberships are calculated based on the FULL and ASSOCIATE rates.
- Visit [www.w7dk.org](http://www.w7dk.org) For the latest and most current information on events and activities

**MEMBERSHIP APPLICATION**  
**CLICK HERE!**

HAVE A SUBMISSION FOR OUR NEXT ISSUE?

[loggersbark@W7DK.org](mailto:loggersbark@W7DK.org)